

# DIGITAL CONTROLLER PXH

DATA SHEET

PXH9

PXH9 is a 96 × 96 mm, high-performance digital controller that assures high-speed and high-accuracy control. With its abundant and flexible input/output points and powerful math function, it can be used for a wide range of applications, including not only temperature control but also process control of pressure, flow rate, etc.

## FEATURES

1. High-speed and high-accuracy control
  - High-speed control in sampling cycle of 50 ms
  - Highly accurate input indication of  $\pm 0.1\%$  FS
  - Measurement resolution of 0.01°C (Resistance bulb input)
2. Multitude of input/output points (including options)
  - Universal measurement input: 2 points (Thermocouple/Resistance bulb/Voltage/Current)
  - Auxiliary analog input: 1 point (DC voltage/Potentiometer)
  - Analog output: 2 points
  - Digital input: 9 points
  - Digital output: 9 points
  - Transmitter power supply
3. Substantial communication function
  - PC Loader interface (RS232C) equipped as standard
  - RS485 (Modbus RTU) communication function (Option)
4. Strong math function
  - Applicable to various applications such as correction processing and input switching based on mathematical calculations between multiple inputs. Refer to the list of expressions on page 17 for the type of mathematical expressions.
5. Complex setting achieved by easy operation
  - Equipped with control template function that allows input/output according to control type and automatic allocation of calculation blocks.
6. Totalizer function
  - Input is selectable from any of measurements or a result of math operation.
  - Seven-digit total display
  - Batch control outputs
7. Excellent user-friendliness
  - Multi-function, large LED display with the high level of visibility
  - Provision of three function keys whose function allocation can be changed
  - IP66 waterproof front face (NEMA-4X)
  - Compact size with the depth of only 81.5 mm



## SPECIFICATIONS

### 1. General specifications

- (1) Power supply voltage: 100 V (-15%) to 240 V (+10%) AC, 50/60 Hz
- (2) Power consumption: 15 VA or less (100 V AC)  
20 VA or less (220 V AC)
- (3) Insulation resistance: 20 M $\Omega$  or more (500 V DC)
- (4) Withstand voltage: Power supply  $\leftrightarrow$  All terminals; 1500 V AC for 1 minute  
Relay output  $\leftrightarrow$  All terminals; 1500 V AC for 1 minute  
Others; 500 V AC for 1 minute
- (5) Applicable standard: UL, C-UL, CE Mark

**2. Input section**

**2-1 Measurement value input**

(1) Number of inputs: 1 or 2 (Option)

(2) Input signal type:

- Thermocouple :J, K, R, B, S, T, E, PR40/20, N, PL-II, WRe5-26
- Resistance bulb :Pt100Ω (3-wire)
- Voltage :0 to 10 mV DC, 0 to 50 mV DC, 1 to 5 V DC, 0 to 5 V DC, 0 to 10 V DC
- Current :4 to 20 mA DC, 0 to 20 mA DC

(3) Measurement range:

Refer to the measurement range table (page 16).

(4) Input indication accuracy (Ambient temperature: 23°C):

- Thermocouple: (±0.1%FS±1digit±1°C) or ±1.5°C, whichever is larger
  - Thermocouple B: 0°C to 400°C range; ±5%FS±1digit±1°C
  - Thermocouple R: 0°C to 500°C range; ±1%FS±1digit±1°C
- Resistance bulb input: (±0.1%FS±1digit) or ±0.25°C, whichever is larger
- Voltage input, current input: ±0.1%FS±1digit

(5) Input sampling cycle: 50 ms

(6) Input impedance

- Thermocouple, voltage input (mV): 1 MΩ or more
- Voltage input (V): 1MΩ
- Current input: 250 Ω

(7) Influence of source resistance / Permissible wiring resistance

- Thermocouple, voltage input (mV):0.1%FS per 100 Ω
- Voltage input (V): 0.1%FS per 500 Ω
- Resistance bulb input: 10 Ω or less (per cable)

(8) Permissible input voltage

- Voltage (V) input: +35 V / -10 V DC
- Current input: ±25 mA DC
- Thermocouple/Resistance bulb/Voltage (mV) input: ±5 V DC

(9) Noise reduction ratio

- Normal mode: 40 dB (50/60 Hz)
- Common mode: 120 dB (50/60 Hz)

(10) Input value correction function (Input conditioner)

- User adjustment: ±50%FS both for zero point and span point
- Square-root extractor: OFF or cut point from 0.0 to 125.0%
- First-order lag filter: 0.0 to 900.0 sec
- Linearizer: 16 straight lines

**2-2 Auxiliary analog input (Option)**

(1) Number of inputs: 1

(2) Input signal

- 1) DC voltage: 1 to 5 V DC / 0 to 5 V DC / 0 to 10 V DC
  - Input accuracy: ±0.2%FS
  - Sampling cycle: 100 ms
  - Input impedance: 1 MΩ
  - Influence of source resistance: 0.2%FS per 500 Ω
  - Permissible input voltage: +35 V / -10 V DC
  - Noise reduction ratio
    - Normal mode: 40 dB (50/60 Hz) or more
    - Common mode: 120 dB (50/60 Hz) or more

2) Valve opening feedback signal (Potentiometer)

- Resistance range: 100 Ω ro 10 kΩ 3-wire
- Resolution: ±0.1%FS
- Input accuracy: ±1.0%FS

(3) Input value correction function

- User adjustment: ±50%FS both for zero point and span point
- Square-root extractor: OFF or cut point from 0.0 to 125.0%
- First-order lag filter: 0.0 to 900.0 sec
- Linearizer: 16 straight lines

**2-3 Digital input (DI)**

(1) Number of points:

- Standard: 4 (Di1 to 4)
- Expansion: 5 (9 points in total at max.)

(2) Specifications: Contact or transistor input

(3) Contact capacity:

- 12 V DC, Approx. 2 mA (per point)

(4) Operation pulse width: 200 ms or more

(5) Function: Control mode changeover, EX-MV selection, SV changeover, Control standby, Auto-tuning start, Timer start, Alarm latch cancel.

**2-4 Math function**

(1) Kind of formula:

- 24 kinds, selected by the parameter setting. (see page 17.)

(2) Operation parameter:

- Analog input (PV1, PV2, Ai1),
- Constant (K1 to K16)

(3) Data type: Engineering unit (with floating point)

**3. Output section**

**3-1 Control output**

**3-1-1 Control output 1**

(1) Number of points: 1

(2) Type: Select one from 1 to 4, as shown below.

1. Relay contact output

- Contact structure: SPDT contact (Do4 used)
- Contact capacity: 220 V AC / 30 V DC, 3 A (Resistive load) 220 V AC / 30 V DC, 1 A (Inductive load)
- Contact life: 100,000 operations (rated load)

2. SSR/SSC driver output (Voltage pulse)

- Rating: 12 V DC (10 to 15 V DC) / Maximum current: 20 mA (provided with protection against short circuit)
- Load resistance: 600 Ω or more

3. Current output (4 to 20 mA DC)

- Accuracy: ±0.2%FS
- Linearity: ±0.2%FS
- Load resistance: 600 Ω or less

#### 4. Motorized valve operation pulse output (OPEN, CLOSE output)

- **Contact structure:**  
SPST contact x 2  
(with interlock circuit)
- **Contact capacity:**  
220 V AC / 30 V DC, 1 A  
(Resistive load)  
220 V AC / 30 V DC, 0.3 A  
(Inductive load)
- **Contact life:** 100,000 times or more (rated load)

#### 3-1-2 Control output 2 (Cooling output)

(1) Number of points: 1

(2) Type: Select one from 1 to 3, as shown below.

##### 1. Relay contact output

- **Contact structure:** SPST contact (Do3 used)
- **Contact capacity:**  
220 V AC / 30 V DC, 1 A (Resistive load)  
220 V AC / 30 V DC, 0.3 A (Inductive load)
- **Contact life:** 100,000 operations (rated load)

##### 2. SSR/SSC driver output (Voltage pulse)

- **Rating:** 12 V DC (10 to 15 V DC) / Maximum current: 20 mA (provided with protection against short circuit)
- **Load resistance:** 600  $\Omega$  or more

##### 3. Current output (4 to 20 mA DC)

- **Accuracy:**  $\pm 0.2\%$ FS
- **Linearity:**  $\pm 0.2\%$ FS
- **Load resistance:** 600  $\Omega$  or less

#### 3-2 Digital output (Do)

(1) Number of points:

Standard: 2 (Do3, 4)  
Expansion: Maximum 7 (9 points in total at max.)

(2) Specifications:

- **Contact structure:**  
SPST contact (except for Do4)  
SPDT contact (Do4)
  - **Contact capacity:**  
220 V AC / 30 V DC, 1A (Resistive load)
  - **Contact life:** 100,000 operations (rated load)
- (3) Function: Alarm output, timer output, control output (Do4, Do3)
- (4) Restriction: 4 Do points max. for 2-point measurement input model.
- (5) Others: Do4 or Do3 becomes control output when relay is selected as control output. Do4 becomes control output for motorized valve control type.

#### 3-3 Analog re-transmission output

(1) Number of points: 2 at max.

(2) Type: Current output (4 to 20 mA DC)

- **Accuracy:**  $\pm 0.2\%$ FS
- **Linearity:**  $\pm 0.2\%$ FS
- **Load resistance:** 600  $\Omega$  or less

(3) Output contents:

PV, SV, MV, DV, AIM (Math operation result), MVRB (Valve openings), TV (Totarizer result)

(4) Restriction: The sum of control output (current or SSR/SSC drive), analog re-transmission output and transmitter power supply output is 2 points at maximum.

#### 3-4 Transmitter power supply output

(1) Number of points: 1 at max.

(2) Rating: 24 V DC (17 to 30 V DC), Maximum current; 23 mA (with short circuit protection)

(3) Restriction: The sum of control output (current or SSR/SSC drive), analog re-transmission output and transmitter power supply output is 2 points at maximum.

#### 4. Control function

##### 4-1 Controller type

(1) Control system

- **Advanced PID control with Auto-tuning**

(2) Controller template

Operation block and I/O definition can be selected by parameter setting from available types according to targets of control.

- **Basic type**

1-loop basic PID controller (with math function)  
1-loop SV selectable PID controller (with math function)  
1-loop basic PID controller (without math function)  
1-loop SV selectable PID controller (without math function)  
1-loop input selectable PID controller (with math function)

- **Motorized valve control type**

[With or without valve openings feedback input is selectable]

1-loop motorized valve controller (with math function)  
1-loop SV selectable motorized valve controller (with math function)  
1-loop motorized valve controller (without math function)  
1-loop SV selectable motorized valve controller (without math function)

- **Heating/cooling control type**

1-loop heating/cooling controller (with math function)  
1-loop SV selectable heating/cooling controller (with math function)  
1-loop heating/cooling controller (without math function)  
1-loop SV selectable heating/cooling controller (without math function)

Note:

The control template can only be changed within each of basic type, motorized valve control type, and heating/cooling control type controllers.

#### 4-2 Control parameter

##### 4-2-1 Basic type, motorized valve control type

- **Proportional band (P):**  
0.0 to 999.9%, ON/OFF (2-position) operation at P = 0
- **Integral time (I):**  
0.0 to 3200.0 sec, Integral operation OFF at I = 0
- **Derivative time (D):**  
0.0 to 999.9 sec, Derivative operation OFF at D = 0
- **Anti-reset windup:** 0 to 100% of measurement range
- **Proportion cycle:**  
1 to 150 sec, For SSR/SSC drive or relay output only
- **Hysteresis width:**  
50% of measurement range, for ON/OFF operation only
- **Control cycle:** 50 ms
- **Number of SV and PID groups:** 7 sets
- **Method of changing PID groups:**  
Selected by parameter, SV reference, PV reference

##### 4-2-2 Heating/cooling control type

- **Proportional band on heating side (P):** 0.0 to 999.9%
- **Integral time on heating side (I):**  
0.0 to 3200.0 sec, Integral operation OFF at I = 0
- **Derivative time on heating side (D):**  
0.0 to 999.9 sec, Derivative operation OFF at D = 0
- **Proportional band on cooling side (Pc):** 0.0 to 999.9%
- **Integral time on cooling side (Ic):**  
0.0 to 3200.0 sec, Integral operation OFF at Ic = 0
- **Derivative time on cooling side (Dc):**  
0.0 to 999.9 sec, Derivative operation OFF at Dc = 0
- **Anti-reset windup:** 0 to 100% of measurement range
- **Proportion cycle:**  
1 to 150 sec, For SSR/SSC drive or relay output only
- **Hysteresis width:**  
50% of measurement range, for ON/OFF operation only
- **Control cycle:** 50 ms
- **Number of SV and PID groups:** 7 sets
- **Method of changing PID groups:**  
Selected by parameter, SV reference, PV reference

#### 4-3 Control mode

- (1) **Type of mode:** Auto/Manual/Remote
- (2) **Changeover:** Available via key, Digital input and Communication.
  - Auto ↔ Manual: With balanceless, bumpless transfer
  - Auto/Manual → Remote: With balance, bumpless transfer
  - Auto/Manual ← Remote: With balanceless, bumpless transfer

#### 5. Alarm function

##### 5-1 Number of alarm points

- 8 points for setting

##### 5-2 Type of alarm

- PV value (upper/lower limit, absolute/deviation, band), PV variation ratio, SV upper/lower limit, main unit error

##### <Optional operation>

- **Hold (standby) function**
- **Operation latching**
- **Excitation/non-excitation**
- **Operation delay:** 0 to 9999 sec, 0 to 9999 min

##### 5-3 Alarm output

- Output to DO1 to DO4 and DO11 to DO15 (Allocation change available.)

#### 6. Communication function

##### 6-1 PC Loader interface

- (1) **Number of points:** 1
- (2) **Physical specifications:** EIA RS232C
- (3) **Protocol:** Modbus-RTU
- (4) **Communication method:**  
3-wire, half-duplex bit serial asynchronous system
- (5) **Data type, Data length:**  
8 bits, Parity; Odd/Even/None
- (6) **Communication speed:**  
9600 bps, 19200 bps, 38400 bps
- (7) **Connector:** Connected with miniature jack on bottom face of the main unit (2.5 mm dia., 3-pole)  
\* Special cable is prepared as option.

##### 6-2 RS-485 interface (option)

- (1) **Number of points:** 1
- (2) **Physical specifications:** EIA RS485
- (3) **Protocol:** Modbus-RTU
- (4) **Communication method:**  
2-wire, half-duplex bit serial asynchronous system
- (5) **Data type, Data length:**  
8 bits, Parity; Odd/Even/None
- (6) **Communication speed:**  
9600 bps, 19200 bps, 38400 bps
- (7) **Connection topology:**  
Multi-drop, Up to 32 units can be connected including master device.
- (8) **Communication distance:**  
500 m max. (Total length of connection)

## 7. Other functions

### 7-1 Parameter recipe

- (1) Number of recipe groups: 7 sets
- (2) Number of parameters which can be registered:  
10 parameters
- (3) Method of changing recipe groups:  
Synchronized with the change of PID groups

### 7-2 Totalizer

- (1) Totalized value: -1999999 to 9999999 (7 digits)
- (2) Totalize source: PV1, PV2, Ai1, AiM [MATH result]
- (3) Totalize resolution: XXX.XXXX to XXXXXXX
- (4) Status: RUN/HOLD/RESET
- (5) Totalized value output: via Re-transmission
- (6) Alarm/Batch output: 2 points, via Do1 to Do4
- (7) Totalized data backup:  
30 seconds interval to EEPROM

## 8. Operation/display section

### 8-1 Parameter setting

- Digital setting by UP/DOWN key
- Key-lock function provided
- User function key (3 keys) provided

### 8-2 Display

- (1) Type: LED
- (2) Display contents
  - Measurement value display:  
7 segments, 5 digits (red), character height; 20 mm
  - Setting display: 7 segments, 5 digits (orange), character height; 13 mm
  - Auxiliary display:  
7 segments, 2 digits (orange), character height; 12 mm
  - Bar graph: 12 segments (orange)
  - Status display indicator lamp:  
Standby, control mode, output, alarm

## 9. Processing at power failure

- Memory protection: Non-volatile memory

## 10. Self diagnosis

- System: Program error monitoring performed by watchdog timer

## 11. Operation and storage conditions

- (1) Ambient operating temperature: -10°C to 50°C
- (2) Storage temperature: -20°C to 60°C
- (3) Ambient humidity for use/storage:  
90% RH or less (non-condensing)
- (4) Warm-up time: 15 min or longer

## 12. Structure

- (1) Mounting method: Panel flush mounting
- (2) External terminal: M3 screw terminal
- (3) Case
  - Material: Plastic  
(Flame-resistant, UL94V-0)
  - Color: Gray
- (4) Protection
  - Faceplate: IEC IP66, NEMA-4X-equivalent  
(When mounted on panel with our genuine packing. Waterproof feature unavailable in side-by-side mounting.)
  - Body: IEC IP20 (Provided with slits on top and bottom faces)
  - Terminal section:  
IEC IP00. Terminal cover can be mounted (option).
- (5) External dimension:  
96 (W) x 96 (H) x 81.5 (D) mm  
\* "D" is the depth from the front face of the panel (not including terminal cover).
- (6) Mass: Approx. 500 g

## 13. Range of delivery

- Controller ..... 1 piece
  - Instruction manual ..... 1 piece
  - CD-ROM ..... 1 piece
- Contents: User's manual  
Communication function manual  
PC loader software  
PC loader software manual
- Mounting bracket ..... 2 pieces
  - Waterproof packing ..... 1 piece
  - Terminating resistor ..... 1 piece (only for the model with communication function)

## 14. PC Loader Software

- (1) System requirements
  - PC: DoS/V PC (PC-AT compatible PC)
  - Operation System:  
Confirmed on  
Windows 2000 (English)  
Windows XP (English)
  - RAM: 128MB or more
  - HDD capacity (Empty area): 100 MB or more
  - CD-ROM drive: Required
  - Display resolution: 1024 x 768 dots or more
- (2) Connection to the PXH controller
  - Via PC Loader interface on bottom face of the main unit (Optional dedicated cable is required.)  
or  
Via RS485 communication (RS485 function is necessary for PXH.)

# BLOCK DIAGRAMS (CONTROLLER TEMPLATES)

**Template No. 10** 1-loop basic PID controller (with math function)

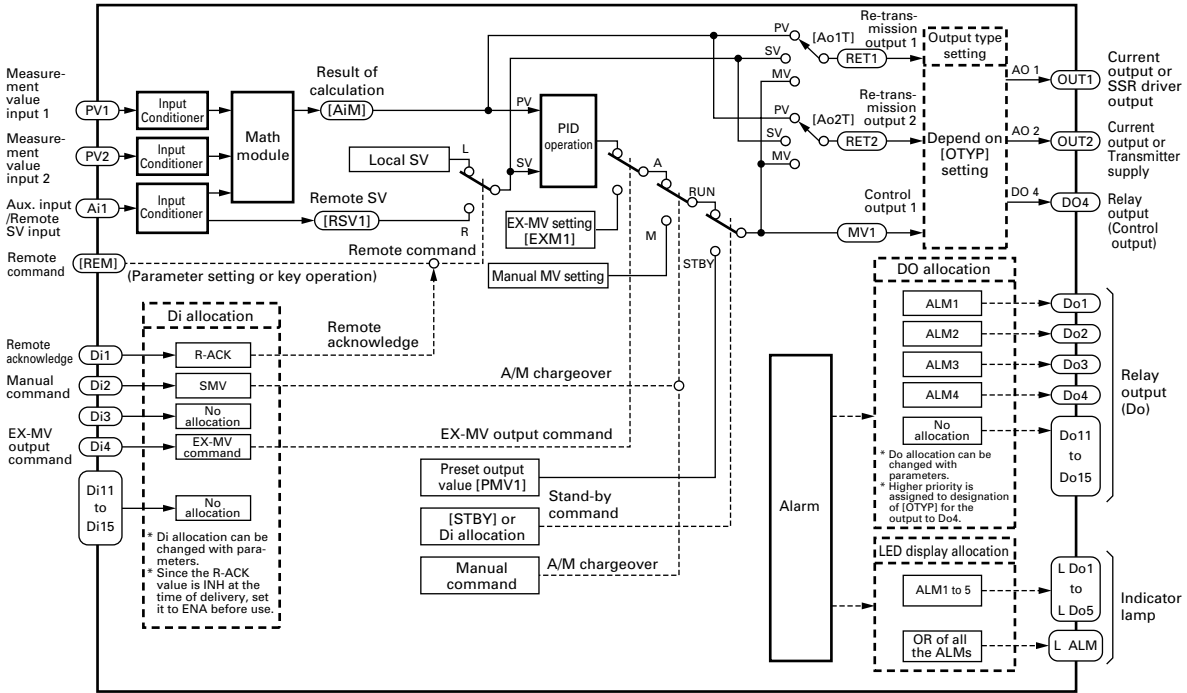

**Template No. 11** 1-loop SV selectable PID controller (with math function)

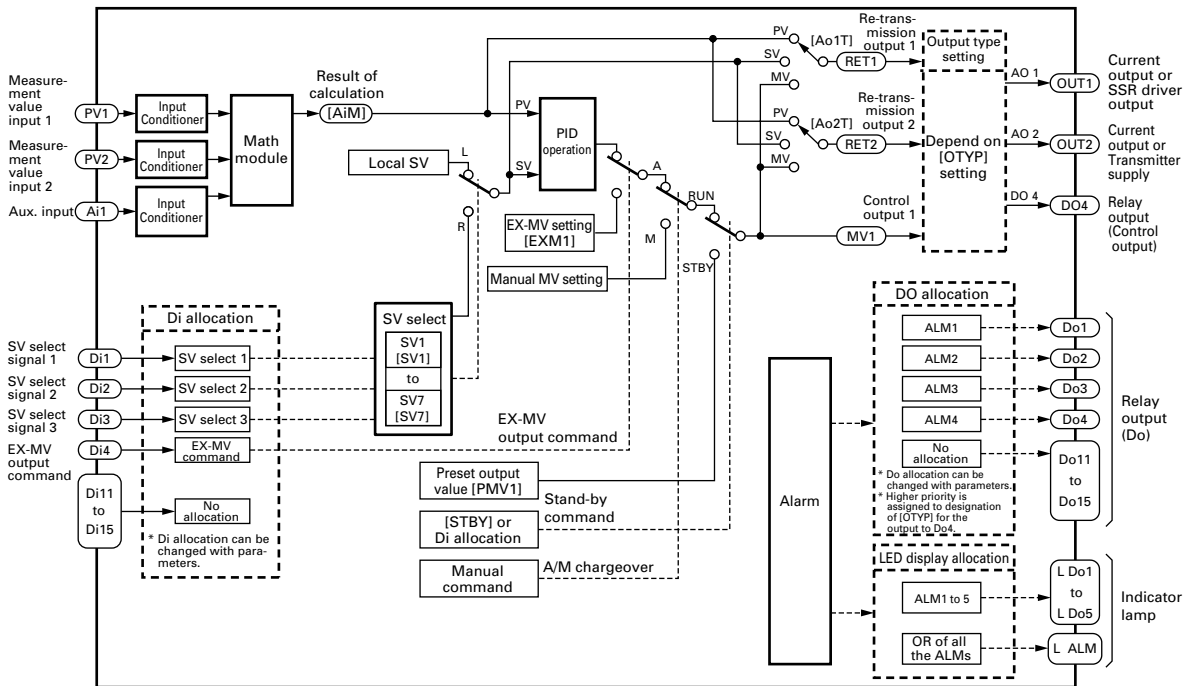

**Template No. 13** 1-loop basic PID controller (without math function)

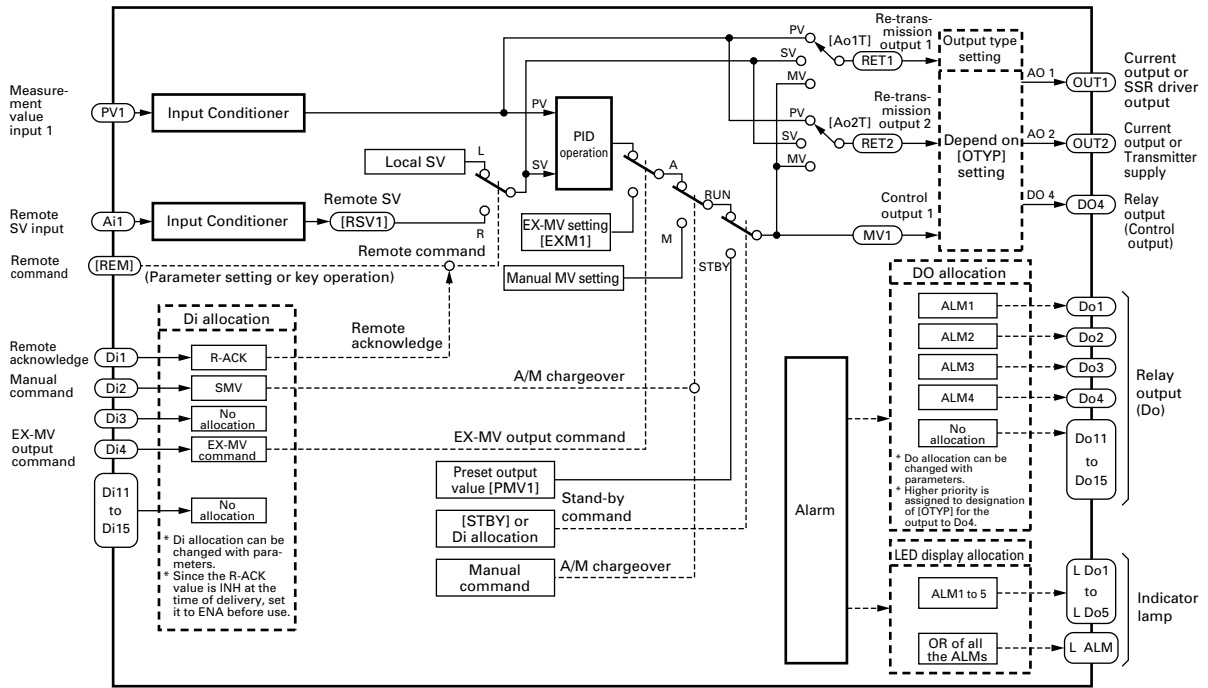

**Template No. 14** 1-loop SV selectable PID controller (without math function)

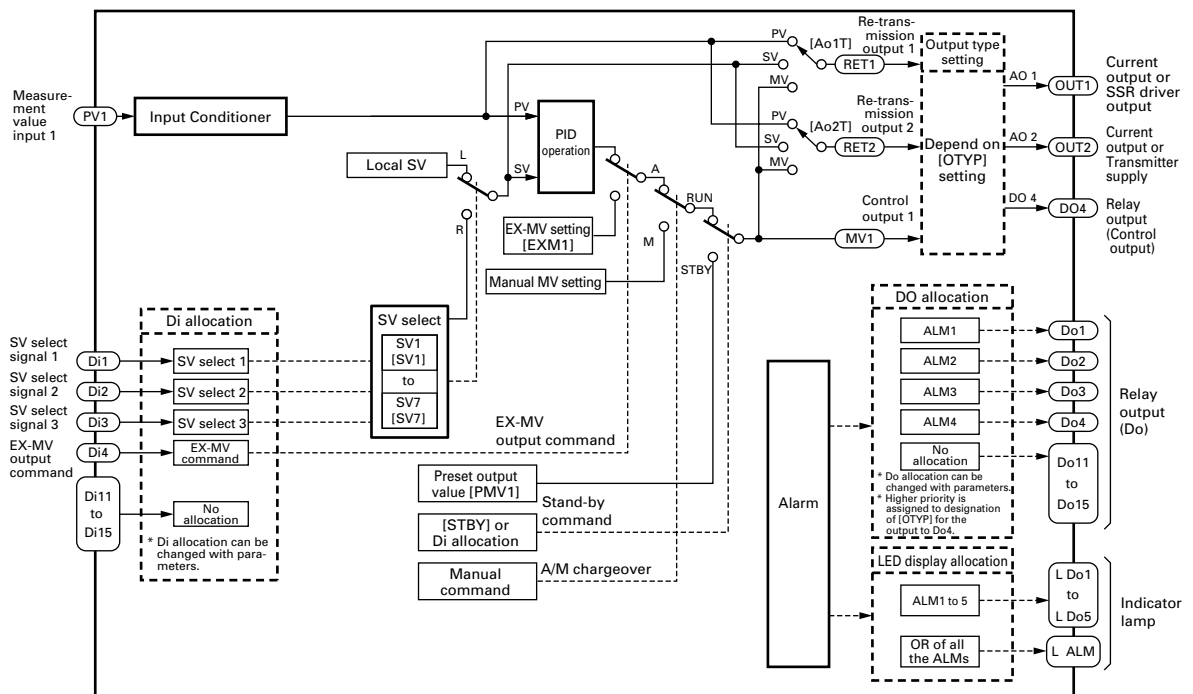

Template No. 16 1-loop input selectable PID controller (with math function)

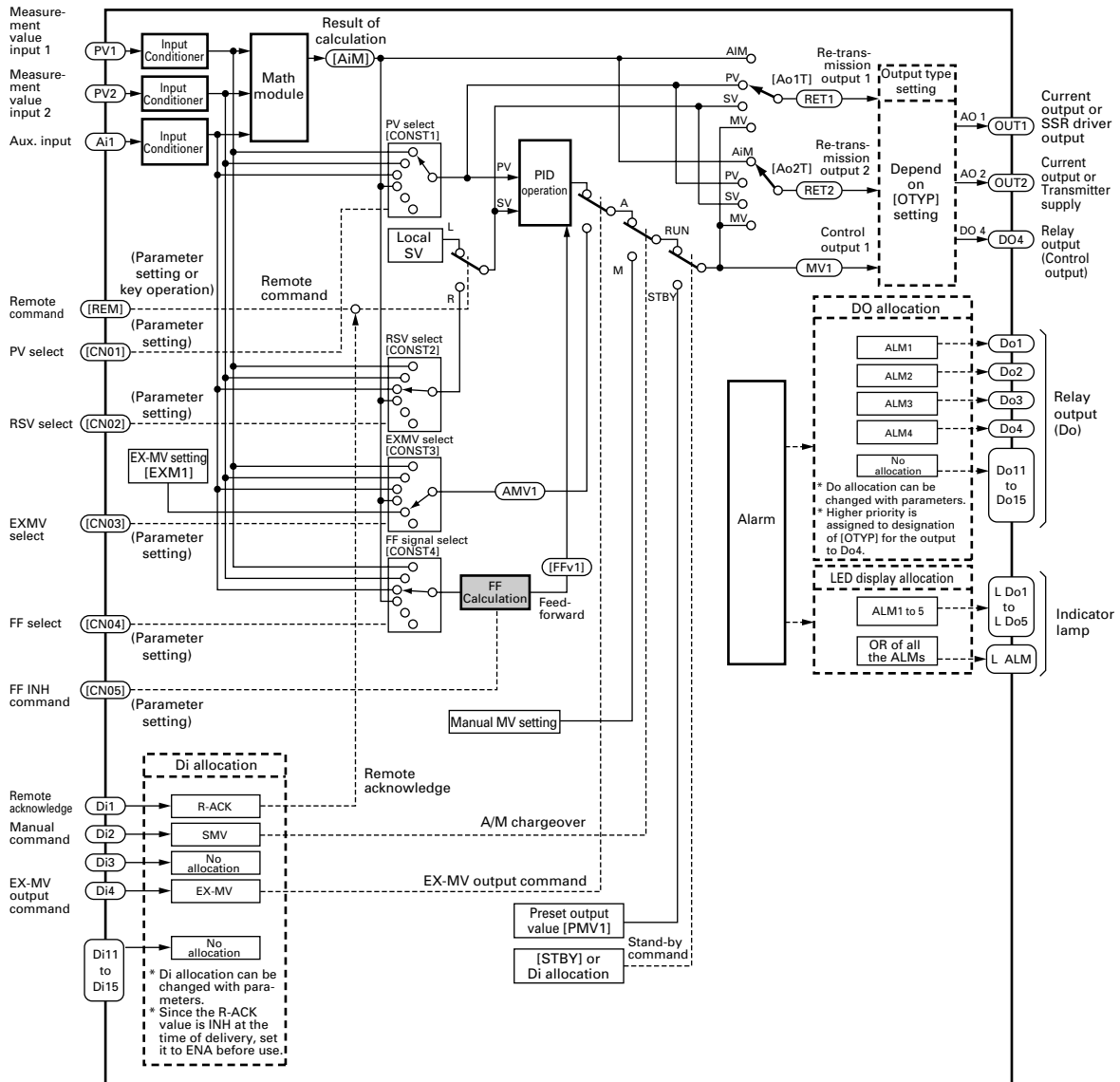



**Template No. 30** 1-loop motorized valve controller (with math function)

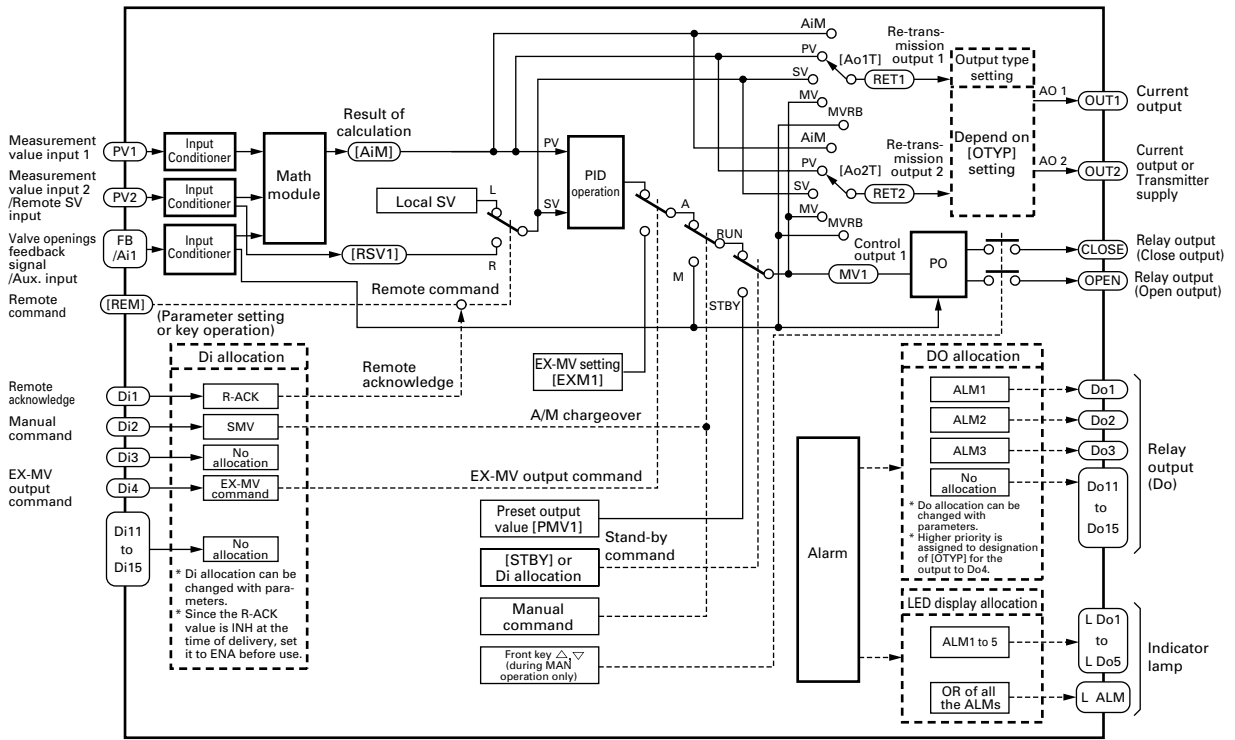

\* Valve openings feedback input is used for the type of 5th digit "D" in CODE SYMBOLS.

**Template No. 31** 1-loop SV selectable motorized valve controller (with math function)

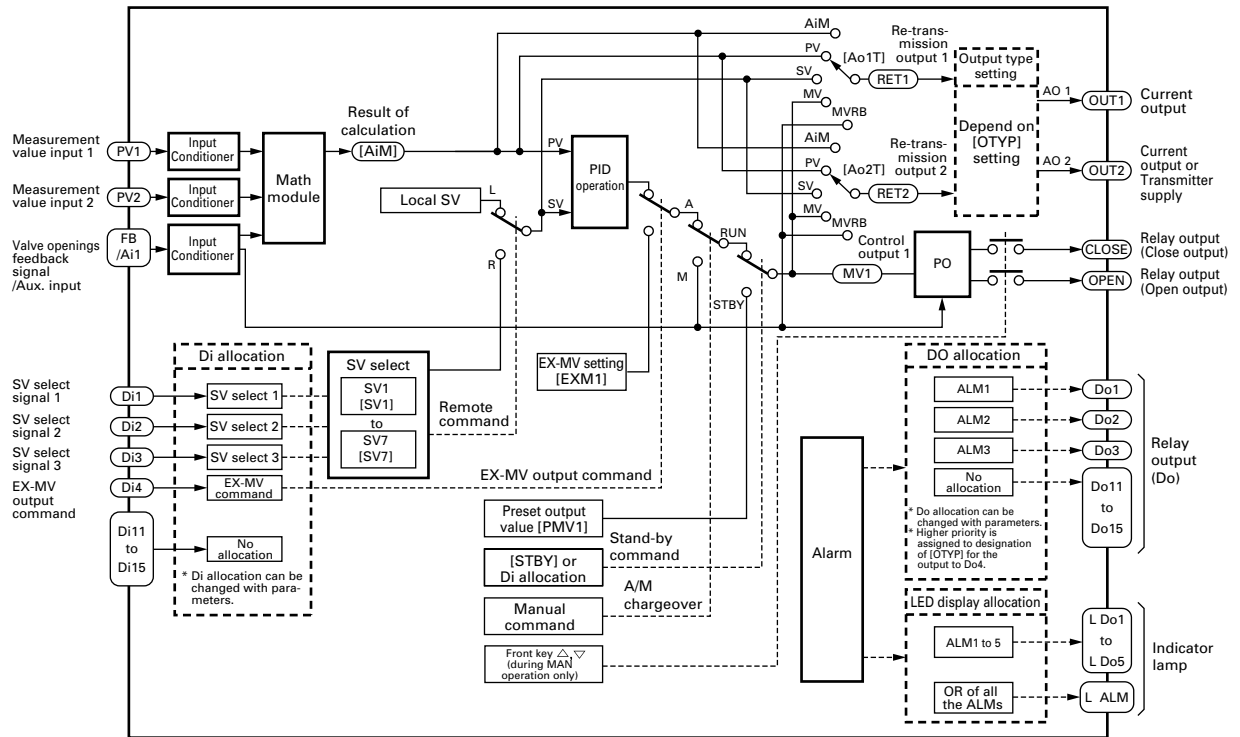

\* Valve openings feedback input is used for the type of 5th digit "D" in CODE SYMBOLS.

**Template No. 33** 1-loop motorized valve controller (without math function)

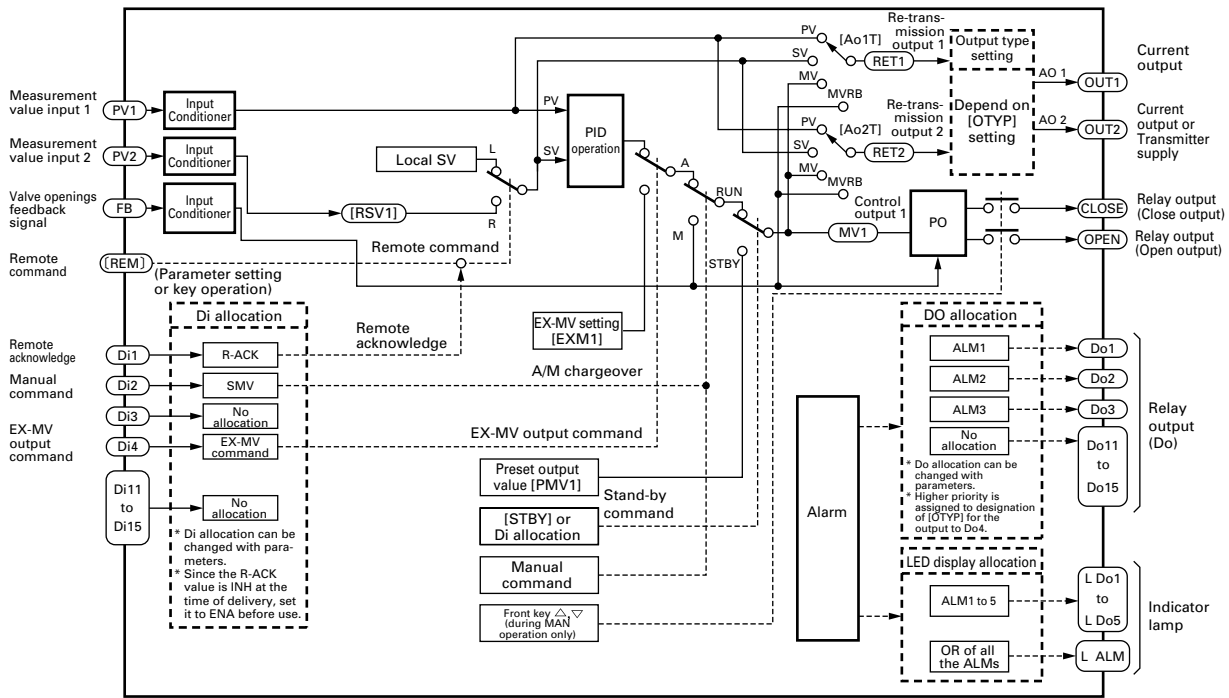

**Template No. 34** 1-loop SV selectable motorized valve controller (without math function)

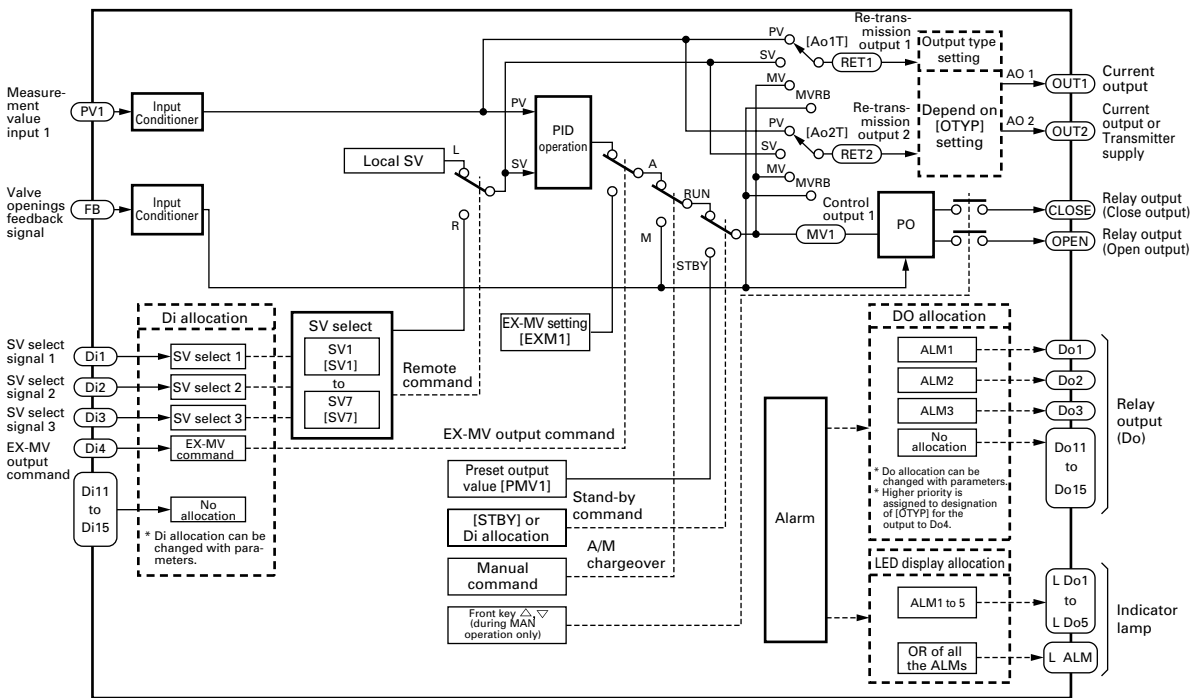

**Template No. 50** 1-loop heating/cooling controller (with math function)

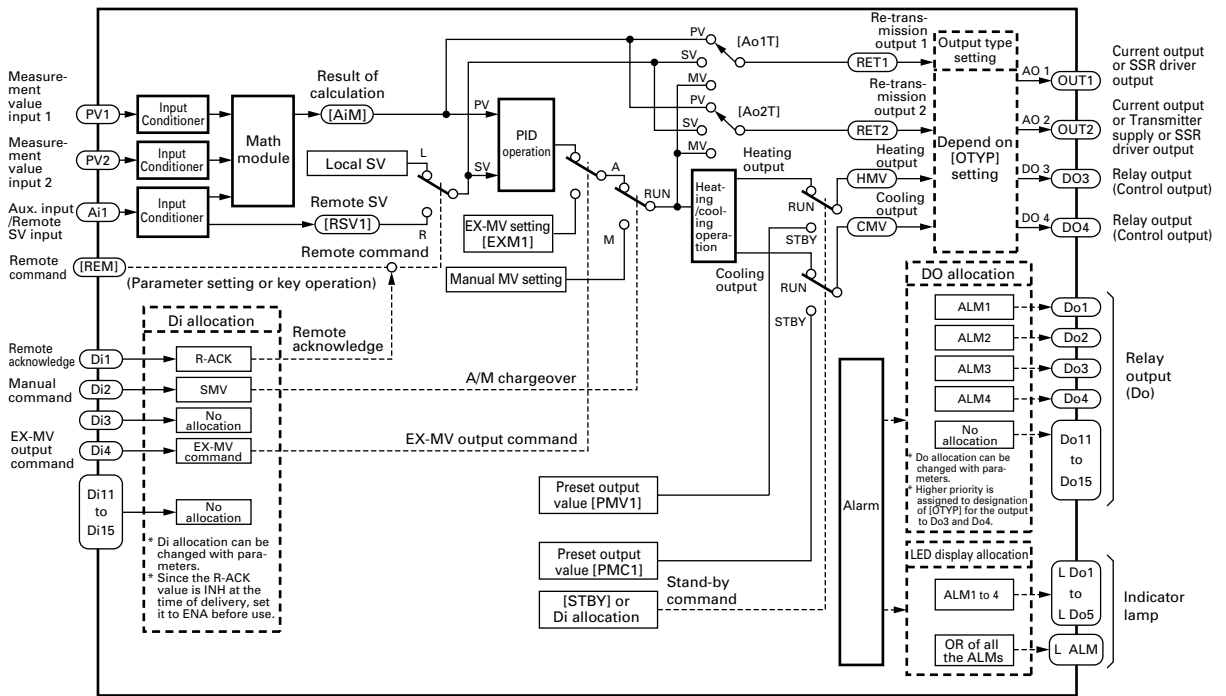

**Template No. 51** 1-loop SV selectable heating/cooling controller (with math function)

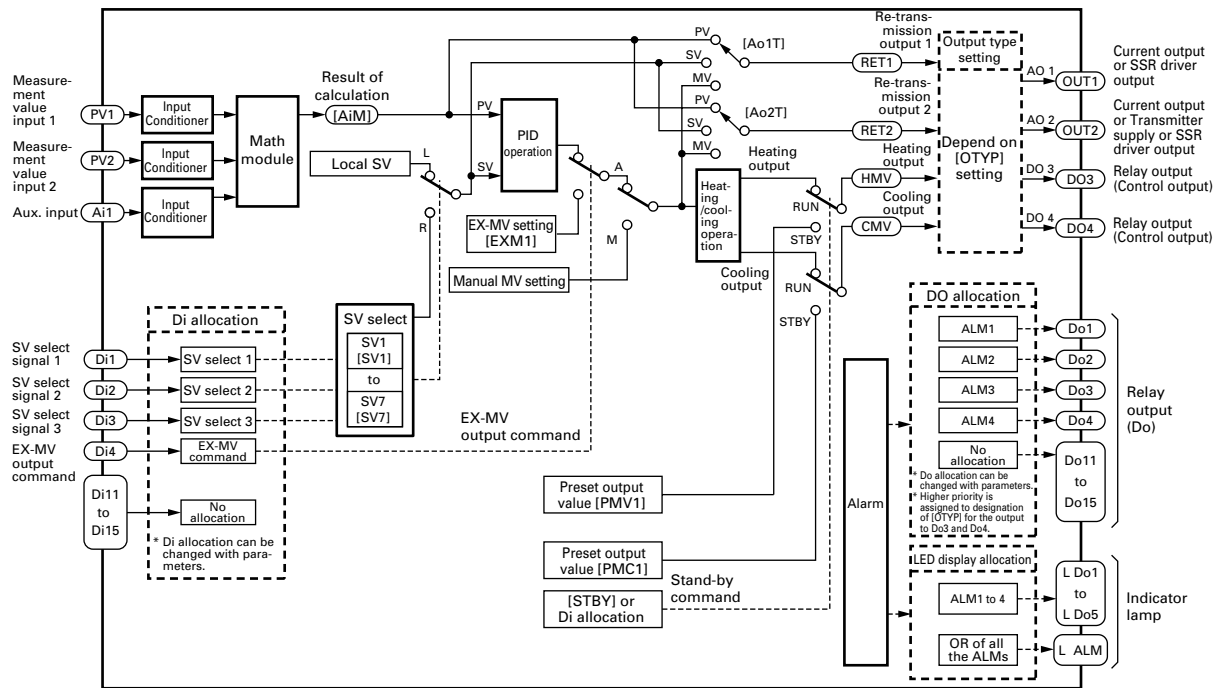

**Template No. 53** 1-loop heating/cooling controller (without math function)

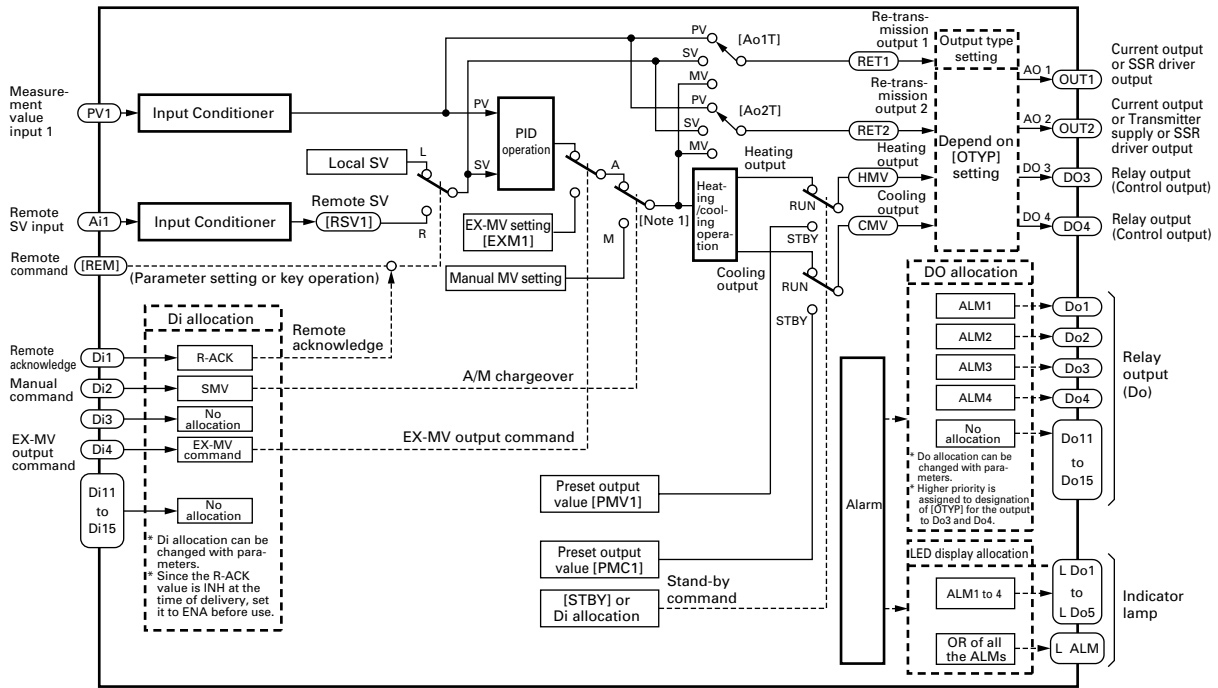

**Template No. 54** 1-loop SV selectable heating/cooling controller (without math function)

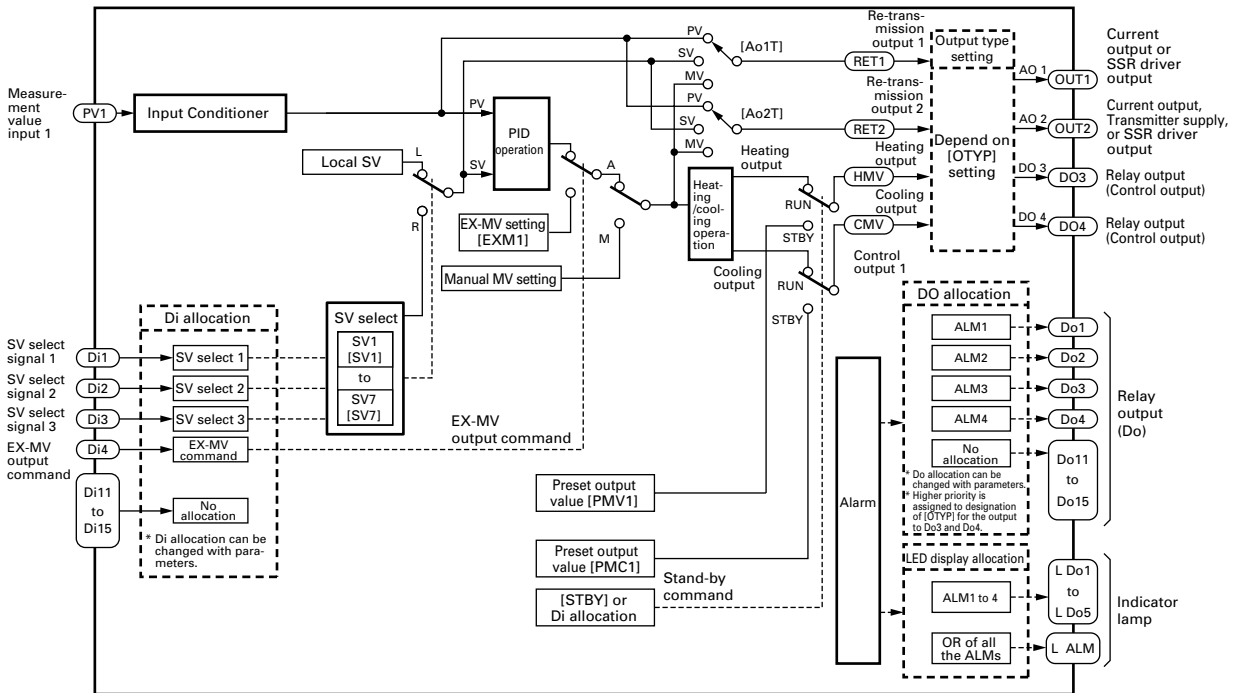

# CODE SYMBOLS [Basic type]

Digit	Description	Notes	1	2	3	4	5	6	7	8	9	10	11	12	13
			P	X	H	9	A	1	1	-	V				0
4	<Dimension of front face H x W> 96 x 96 mm						9								
5	<Number of control loops/Function> 1-loop basic controller						A								
6	<Measurement value input> Universal input: 1 point Universal input: 2 points	*1						1 2							
7	<Auxiliary input> Not fitted DC voltage: 1 point								0 1						
8	<Version No.>									1					
9	<Output> OUT1                      OUT2 <hr/> Current                      Not fitted Current                      Current Current                      Transmitter supply SSR/SSC driver              Not fitted SSR/SSC driver              Current	*3										1 2 5 A B			
10	<Power supply> 100 to 240 V AC											V			
11	<Communication interface> Not fitted RS-485												0 R		
12	<Digital input/output> Digital input                      Digital output (Including relay control output) <hr/> 4 points (Di1 to Di4)                      2 points (Do3, Do4) 4 points (Di1 to Di4)                      4 points (Do1 to Do4) 9 points (Di1 to Di4, Di11 to Di15)                      9 points (Do1 to Do4, Do11 to Do15)	*2  *1												0 A B	
13	<Additional specifications> Not fitted.														0

\*1: "2" for the 6th digit and "B" for the 12th digit cannot be specified at the same time.  
 \*2: One digital output (Do4) is occupied when relay is allocated as control output.  
 \*3: Explanation of the 9th digit of type code and output terminal function is below.

Code	9th digit	Terminal	Do4	OUT1		OUT2	
		Output Kind	Relay	Current (4 to 20 mA)	SSR/SSC driver	Current (4 to 20 mA)	Transmitter power supply
		Function *	Control output or Digital output	Control output or Re-transmission output	Control output	Re-transmission output	
	1	○	○	—	—	—	
	2	○	○	—	○	—	
	5	○	○	—	—	○	
	A	○	—	○	—	—	
	B	○	—	○	○	—	

— : Not fitted  
 ○ : Fitted

\* The selection of "Function" is specified according to the parameter.

## Optional Items

Contents	Model	Notes
Terminal cover	ZZP PXR1-B230	Two pieces are necessary per 1 unit.
PC loader interface cable	ZZP PXH1*TK4H4563	For RS232C Interface

[Motorized valve control type]

Digit	Description	Notes	1	2	3	4	5	6	7	8	9	10	11	12	13
4	<Dimension of front face H x W> 96 x 96 mm		P	X	H	9					-	V			0
5	<Number of control loops/Function> 1-loop motorized valve controller (with valve openings feedback input) 1-loop motorized valve controller (without valve openings feedback input)						D	S							
6	<Measurement value input> Universal input: 1 point Universal input: 2 points	*1					1	2							
7	<Auxiliary input> Not fitted DC voltage: 1 point								0	1					
8	<Version No.>									1					
9	<Output> OUT1                      OUT2 ----- Current                      Not fitted Current                      Current Current                      Transmitter supply	*2										1	2	5	
10	<Power supply> 100 to 240 V AC											V			
11	<Communication interface> Not fitted RS-485												0	R	
12	<Digital input/output> Digital input                      Digital output (Including valve control output) ----- 4 points (Di1 to Di4)                      2 points (Do3, Do4) 4 points (Di1 to Di4)                      4 points (Do1 to Do4) 9 points (Di1 to Di4, Di11 to Di15)                      9 points (Do1 to Do4, Do11 to Do15)	*3   *1												0	A B
13	<Additional specifications> Not fitted.														0

- \*1: Universal input 2 points and "B" for the 12th digit cannot be specified at the same time. Select "universal input 2 points" when external setting input (RSV) is required.
- \*2: "D" for the 5th digit and "1" for the 7th digit cannot be specified at the same time.
- \*3: Do4 is used as control output. If 2 or 3 Do points are required for event output, specify code A, and if 4 to 8 Do points are required, specify code B.

Code	Terminal	Do4	OUT1	OUT2	
	Output kind	Relay	Current (4 to 20 mA)	Current (4 to 20 mA)	Transmitter power supply
Function *	Function *	Used for valve open/close output.	Re-transmission output	Re-transmission output	Transmitter power supply
9th digit	1	○	○	—	—
	2	○	○	○	—
	5	○	○	—	○

— : Not fitted  
○ : Fitted

\* The selection of "Function" is specified according to the parameter.

# [Heating/cooling control type]

Digit	Description	Notes	1	2	3	4	5	6	7	8	9	10	11	12	13
4	<Dimension of front face H x W> 96 x 96 mm		P	X	H	9	F			1		V			0
5	<Number of control loops/Function> 1-loop heating/cooling controller						F								
6	<Measurement value input> Universal input: 1 point Universal input: 2 points	*1						1	2						
7	<Auxiliary input> Not fitted DC voltage: 1 point							0	1						
8	<Version No.>								1						
9	<Output> OUT1                      OUT2  Current                      Not fitted Current                      Current Current                      SSR/SSC drive Current                      Transmitter supply SSR/SSC driver              Not fitted SSR/SSC driver              Current SSR/SSC driver              SSR/SSC drive	*3									1	2	3	5	A B C
10	<Power supply> 100 to 240 V AC											V			
11	<Communication interface> Not fitted RS-485												0	R	
12	<Digital input/output> Digital input                      Digital output (Including relay control output)  4 points (Di1 to Di4)              2 points (Do3, Do4) 4 points (Di1 to Di4)              4 points (Do1 to Do4) 9 points (Di1 to Di4, Di11 to Di15)      9 points (Do1 to Do4, Do11 to Do15)	*2  *1												0	A B
13	<Additional specifications> Not fitted.														0

- \*1: "2" for the 6th digit and "B" for the 12th digit cannot be specified at the same time.
- \*2: One digital output (Do4) or 2 points (Do3 and 4) is occupied when relay is allocated as control output.
- \*3: Explanation of the 9th digit of type code and output terminal function is below.

Code	9th digit	Terminal	Do3	Do4	OUT1		OUT2		Transmitter power supply
		Output kind	Relay	Relay	Current (4 to 20 mA)	SSR/SSC driver	Current (4 to 20 mA)	SSR/SSC driver	
Function *		Control output or Digital output	Control output or Digital output	Control output or Digital output	Control output or Re-transmission output	Control output	Control output or Re-transmission output	Control output	
	1	○	○	○	—	—	—	—	—
	2	○	○	○	—	○	—	—	—
	3	○	○	○	—	—	○	—	—
	5	○	○	○	—	—	—	○	—
	A	○	○	—	○	—	—	—	—
	B	○	○	—	○	○	—	—	—
	C	○	○	—	○	—	○	—	—

\* The selection of "Function" is specified according to the parameter.

## MEASUREMENT RANGE TABLE

(1) Unit of temperature : °C

Input type		Measurement range [°C]		Reading/setting resolution (°C)			
		Max.	Min.				
Resistance bulb	Pt100Ω	-150 to 850	0 to 150	0.01			
Thermocouple	J	0 to 1000	0 to 400	0.1			
	K	0 to 1200	0 to 400	0.1			
	R	0 to 1600	0 to 1600	0.1			
	B	0 to 1800	0 to 1800	0.1			
	S	0 to 1600	0 to 1600	0.1			
	T	-200 to 400	-200 to 200	0.1			
	E	-200 to 800	0 to 800	0.1			
	PR40/20	0 to 1800	0 to 1800	0.1			
	N	0 to 1300	0 to 1300	0.1			
	PL-II	0 to 1300	0 to 1300	0.1			
	WRe5-26	0 to 2300	0 to 2300	0.1			
DC voltage	1 to 5 V	-19999 to 99999 (Range where scaling is allowed)		1/10000 digit			
	0 to 5 V						
	0 to 10 V						
	0 to 10 mV						
	0 to 50 mV						
DC current	4 to 20 mA						
	0 to 20 mA						
Motorized valve opening feedback	Potentiometer				100 to 10 kΩ		1/1000 digit

(2) Unit of temperature : °F

Input type		Measurement range [°F]		Reading/setting resolution (°F)			
		Max.	Min.				
Resistance bulb	Pt100Ω	-238 to 1562	32 to 302	0.01			
Thermocouple	J	32 to 1832	32 to 752	0.1			
	K	32 to 2192	32 to 752	0.1			
	R	32 to 932	32 to 932	0.1			
	B	32 to 3272	32 to 3272	0.1			
	S	32 to 2912	32 to 2912	0.1			
	T	-328 to 752	-328 to 392	0.1			
	E	-328 to 1472	32 to 1472	0.1			
	PR40/20	32 to 3272	32 to 3272	0.1			
	N	32 to 2372	32 to 2372	0.1			
	PL-II	32 to 2372	32 to 2372	0.1			
	WRe5-26	32 to 4172	32 to 4172	0.1			
DC voltage	1 to 5V DC	-19999 to 99999 (Range where scaling is allowed)		1 / 10000 digit			
	0 to 5V DC						
	0 to 10V DC						
	0 to 10mV DC						
	0 to 50mV DC						
Current	4 to 20mA DC						
	0 to 20mA DC						
Motorized valve opening feedback	Potentiometer				100 to 10 kΩ		1/1000 digit



# LIST OF MATH FUNCTIONS

CALC setting	Name of operation	Arithmetic expression
0	No math operation	M1 = PV1 input
1	Mathematical expression 1 (Flow rate compensation with temperature and pressure)	$M1 = k01 \times \sqrt[1]{PV1} \times \sqrt[2]{\frac{Ai1 + k02}{k03} \times \frac{k04}{PV2 + k05}}$ PV1: Flow rate (differential pressure), PV2: Temperature, Ai1: Pressure
2	Mathematical expression 2 (Flow rate compensation with temperature and pressure)	$M1 = k01 \times PV1 \times \sqrt[1]{\frac{Ai1 + k02}{k03} \times \frac{k04}{PV2 + k05}}$ PV1: Flow rate (differential pressure), PV2: Temperature, Ai1: Pressure
3	Mathematical expression 3 (Flow rate compensation with temperature and pressure)	$M1 = k01 \times PV1 \times \frac{Ai1 + k02}{k03} \times \frac{k04}{PV2 + k05}$ PV1: Flow rate (differential pressure), PV2: Temperature, Ai1: Pressure
4	Mathematical expression 4	$M1 = \frac{(k01 \times (k02 \times PV1 + k03 \times PV2 + k04 \times Ai1) + k05)}{(k06 \times (k07 \times PV1 + k08 \times PV2 + k09 \times Ai1) + k10)}$
5	Mathematical expression 5	$M1 = \frac{(k01 \times ((k02 \times PV1 + k03) \times (k04 \times PV2 + k05) \times (k06 \times Ai1 + k07))) + k08}{(k09 \times ((k10 \times PV1 + k11) \times (k12 \times PV2 + k13) \times (k14 \times Ai1 + k15)) + k16)}$
6	Mathematical expression 6	$M1 = k01 \times PV1 \times (k02 \times PV2 + k03 \times Ai1) + k04 \times Ai1 + k05$
7	H selector (2 points)	M1 = Max (PV1, PV2) PV1 or PV2, whichever is larger, is selected.
8	L selector (2 points)	M1 = Min (PV1, PV2) PV1 or PV2, whichever is smaller, is selected.
9	H selector (3 points)	M1 = Max (PV1, PV2, Ai1) PV1, PV2, or Ai1, whichever is largest, is selected.
10	L selector (3 points)	M1 = Min (PV1, PV2, Ai1) PV1, PV2, or Ai1, whichever is smallest, is selected.
11	Input switching (2 points)	M1 = PV1 when PV1 ≤ k01, M1 = PV2 when PV1 > k01
12	H/L selector (2 points) (with Di switching function)	Expression 7 or 8 is used by Di switching. (Specify "140" for Di function for switching.)
13	H/L selector (3 points) (with Di switching function)	Expression 9 or 10 is used by Di switching. (Specify "140" for Di function for switching.)
20	Flow rate compensation with temperature and pressure [% value operation]	$M1 = \sqrt{PV1 \times \frac{(Ai1 + k01) + k02}{(PV2 \times k03) + k04}}$ PV1: Differential pressure (flow rate) % value, k01: Pressure compensation constant 1, k04: Temperature compensation constant 2 PV2: Fluid temperature % value, k03: Temperature compensation constant 1 Ai1: Differential pressure % value, k02: Pressure compensation constant 2, k05: Square-root extractor cut point *Input data: % value (0 (0%) to 100000 (100.000%))
21	Flow rate compensation with temperature and pressure [% value operation] (without square-root extraction)	$M1 = PV1 \times \frac{(Ai1 \times k01) + k02}{(PV2 \times k03) + k04}$ All the inputs and constants are of the same specifications as mathematical expression 20.
27	H selector (2 points) (with coefficient)	M1 = max ((PV1 X k01 + k02), (PV2 X k03 + k04))
28	H selector (2 points) (with coefficient)	M1 = min ((PV1 X k01 + k02), (PV2 X k03 + k04))
29	H selector (3 points) (with coefficient)	M1 = max ((PV1 X k01 + k02), (PV2 X k03 + k04), (Ai X k05 + k06))
30	L selector (3 points) (with coefficient)	M1 = min ((PV1 X k01 + k02), (PV2 X k03 + k04), (Ai X k05 + k06))
31	Input switching (2 points) (with coefficient)	M1 = (PV1 X k02 + k03) when k01 > (PV1 X k02 + k03) M1 = (PV2 X k04 + k05) when k01 ≤ (PV1 X k02 + k03)
32	H/L selector (2 points) (with Di switching function)	Expression 27 or 28 is used by Di switching. (Specify "140" for Di function for switching.)
33	H/L selector (3 points) (with Di switching function)	Expression 29 or 30 is used by Di switching. (Specify "140" for Di function for switching.)
34	Input switching (2 points) (with coefficient and interpolation function)	When PV1 ≤ k05 : M1 = (PV1 X k01) + k02 When PV2 ≤ k06 : M1 = (PV2 X k03) + k04 When PV1 > k05 and PV2 < k06 : Interpolation shown below, is executed. $M1 = \left(1 - \frac{(PV1 \times k01 + k02) - k05}{k06 - k05}\right) \times (PV1 \times k01 + k02) - k05 - \left(\frac{(PV1 \times k01 + k02) - k05}{k06 - k05}\right) \times (PV2 \times k03 + k04)$ * note) k05 : Input switching upper value k06 : Input switching lower value
40	Calorie calculation	M1 = ((PV1 X k01 + k02) - (PV2 X k03 + k04)) X (Ai1 X k05 + k06))

\*1: Square-root extraction cut point can be set with k06.

\*2: Square-root extraction cut point can be set with k07.

OUTLINE DIAGRAM (Unit:mm)

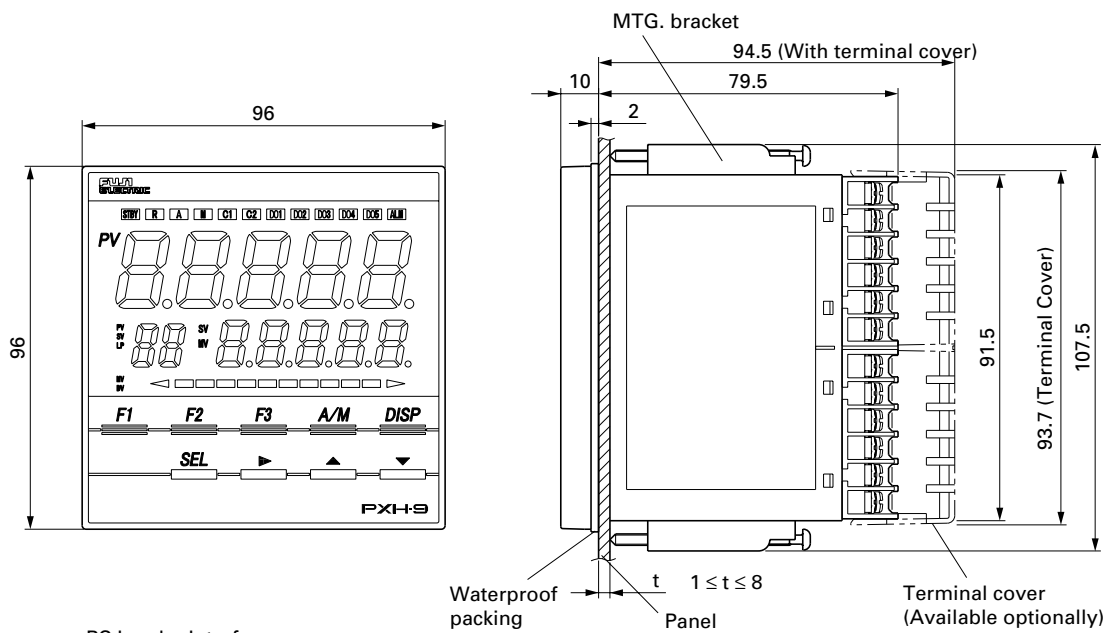

PC Loader Interface

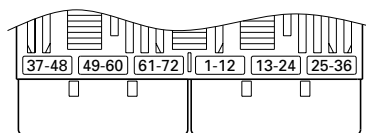
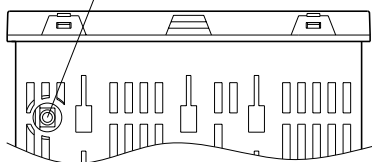

PANEL CUTOUT

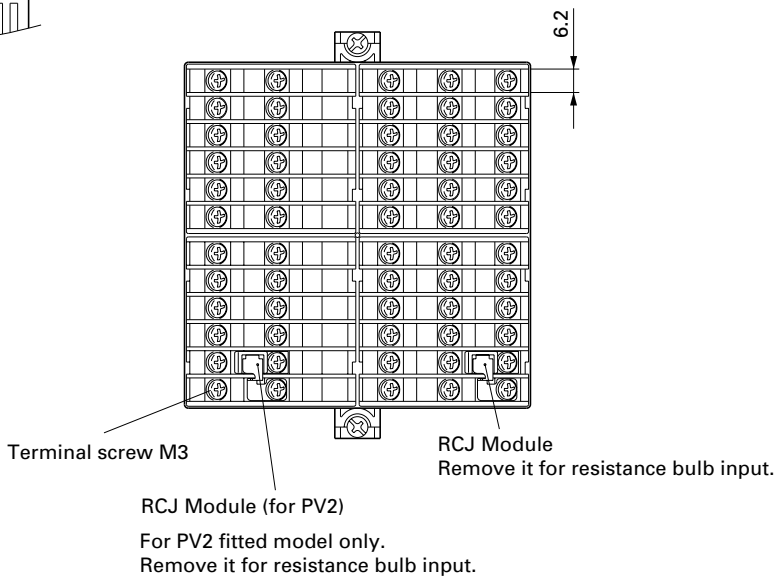
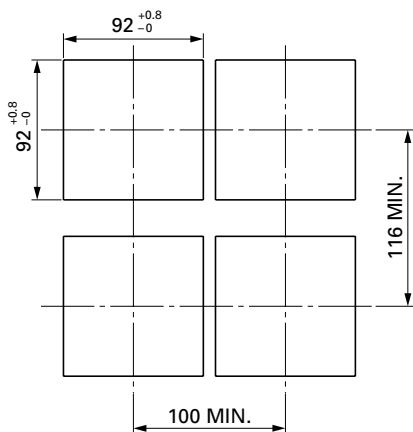

In some models, a terminal block is not mounted to terminals those are not being used (terminal Nos. 37 to 60). (A dummy cover is mounted instead.)

# TERMINAL ALLOCATION

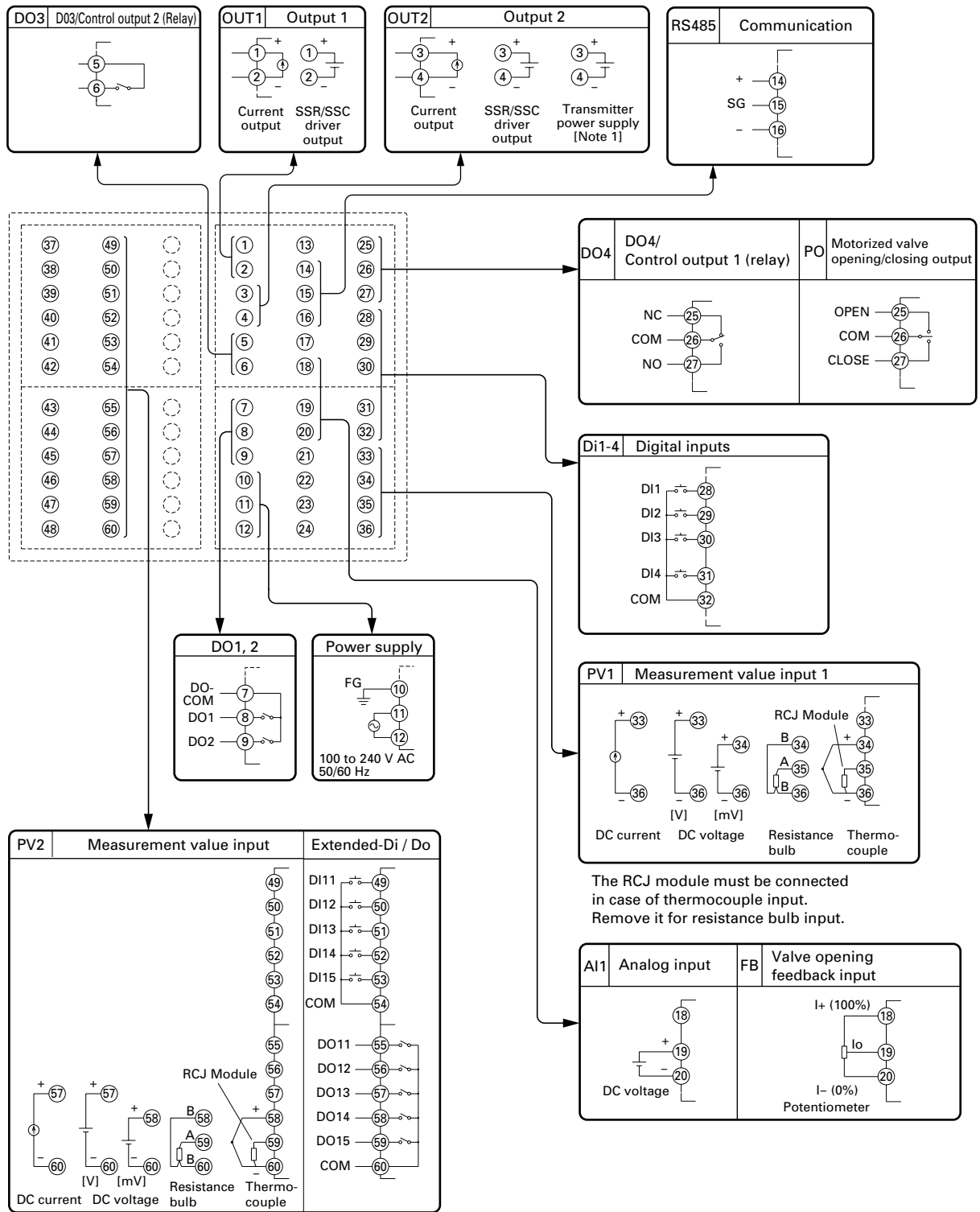

The RCJ module must be connected in case of thermocouple input. Remove it for resistance bulb input.

[Note1] Connection to the transmitter power supply

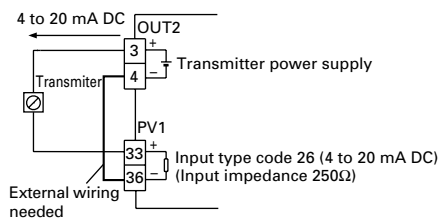

## INSULATION BLOCK DIAGRAM

Power source	Internal Circuit
Digital output (DO) 1, 2	PC Loader interface
Digital output (DO) 3	Measurement value input 1 (PV1)
Digital output (DO) 4	Measurement value input 2 (PV2)
Digital output (DO) 11 to 15	Auxiliary analog Input 1 (Ai1) / Valve openings feedback input (FB)
	Output 1 (Current / SSR driver)
	Output 2 (Current / SSR driver)
	Digital input (DI) 1 to 4
	Digital input (DI) 11 to 15
	Transmitter power supply
	RS485

—————	Basic insulation (1500 V AC)
—————	Functional insulation (500 V AC)
-----	No insulation

⚠ Caution on Safety

\*Before using this product, be sure to read its instruction manual in advance.

### Fuji Electric Systems Co., Ltd.

#### Head Office

Gate City Ohsaki, East Tower, 11-2, Osaki 1-chome,  
Shinagawa-ku, Tokyo 141-0032, Japan

<http://www.fesys.co.jp/eng>

#### Instrumentation Div.

#### International Sales Dept.

No.1, Fuji-machi, Hino-city, Tokyo, 191-8502 Japan

Phone: 81-42-585-6201, 6202 Fax: 81-42-585-6187

<http://www.fic-net.jp/eng>

Information in this catalog is subject to change without notice.

Printed in Japan