

Advanced[®]

CONTROL

Assembly- and Commissioning Instructions
Softstarters
VS II ... - 50 ... 75

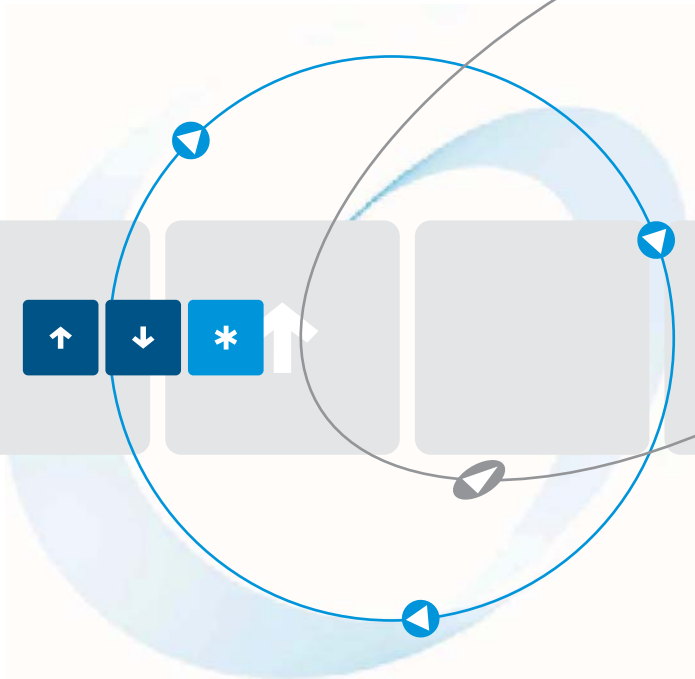

Quality is our Drive.

as per 07/10 15700.10008

Table of Contents	Page
1. Safety notes	3
2. Conformity	3
3. General description	4
4. Usage to the intended purpose	4
5. EC Declaration of Conformity	5
6. Block diagram	6
7. Commissioning	6
7.1 Mounting instructions	6
7.2 Connection	8
7.3 Adjusting the control type	8
7.4 Parameter settings	9
7.5 Current-controlled start	11
7.6 Starting frequency	13
7.7 Devices with motor-PTC input	13
8. LED indicators	14
9. Fault	14
9.1 Fault description	15
9.2 Fault remedy	16
9.3 Resetting of faults	16
10. Technical data (standard) *	17
10.1 Environmental conditions	18
11. Dimensioning rules	18
11.1 Dimensioning of pre-fuses	18
11.2 Determining the permissible starting frequency	20
12. Special units	22
12.1 Devices with rated voltage of 230V or 480V	22
12.2 Devices featuring a wide-voltage-range power section	22
12.3 Devices featuring special voltage $\geq 500V$	22
13. Installation guidelines	22
13.1 Connection	22
13.1.1 Earthing	22

13.1.2	Cabling	23	
13.2	General connection diagram		24
13.3	Typical connections		25
13.4	Connection with motor contactor		26
13.5	Motor/Soft start in delta connection		26
13.6	Wide-voltage-range connection		27
14.	Dimensions		28
15.	Special units		28

These commissioning instructions were prepared with great care. Nevertheless, Advanced Control does not assume liability for damage resulting from mistakes possibly contained in this manual. Technical changes that serve to improve the product are subject to change without notice.

Notes and symbols used in these instructions

Note: Notes explain the advantages of certain adjustments or settings and help you to make use of the device in the best possible way.



Warning notices: Read them carefully and follow them strictly!

Warning notices are indicated in order to protect you against danger or to help you to prevent the device from being damaged.



Caution: Danger to life through electric shock!

When you see this sign, always make sure that the device is de-energized and secured against unintentional energizing.

1. Safety notes



The described devices are electrical equipment for use in industrial electrical power installations. An impermissible removal of the covers during operation can cause serious damage to your health, since these devices contain live parts with high voltages.

Adjustment work may only be performed by trained staff observing the safety regulations. Assembly and mounting work may only be carried out with the equipment deenergized.

Make sure that all drive components are properly earthed.

Please read these commissioning instructions carefully before putting the device into operation.

Besides, the user must ensure that the devices and associated components are fitted and connected in accordance with the applicable local, legal and technical regulations. The VDE-regulations VDE 0100, VDE 0110 (EN 60664), VDE 0160 (EN 50178) , VDE 0113 (EN 60204, EN 61310), VDE 0660 (EN 50274) plus the appropriate regulations of the TÜV (Technical Control Association) and the trade associations apply in Germany.

The user must ensure that the drive turns into a safe operating state following a device failure, in the event of maloperation, or if the control unit has failed etc..

Caution: Even if the motor is at rest, it is **not** physically separated from the mains.

2. Conformity

In industrial linguistic usage the drive controllers of the type series VersiStart II are called "devices", however, in the sense of the "law on the safety of equipment", the "EMC-law" or the "EC-machinery directive" they are not devices or machines ready for use or connection but they are components. It is only possible to define their final function, when these components are integrated into the design and construction of the user.

To be able to use the devices to their intended purpose, it requires power supply networks according to DIN EN 50160 (IEC38).

The user takes the responsibility that the user's design and construction comply with the applicable legal provision.

The commissioning is strictly forbidden as long as the conformity of the final product with the guidelines 2006/42/EC (Machinery directive) and 2006/95/EC (Low voltage directive) is not proved.

3. General description

Ramp control:

In the case of the soft starters of the VersiStart II type the motor voltage is changed in two phases (1L1/5L3) by a generalized phase control and power semiconductors. Starting from an adjustable starting trigger angle the trigger angle is continually reduced. Via the adjusted ramp-up time the motor voltage increases according to a ramp function until the maximum value is reached. When the acceleration time is over, the power semiconductors are bypassed by integrated relays and the motor is directly supplied with power from the mains.

Current control:

If VersiStart II is operated with an external current transformer, current-controlled starts are implemented. In this connection, the motor voltage is increased via a ramp function until the adjusted starting current is reached. With this starting current, the drive is further accelerated until the motor current decreases to approx. nominal current. Now, the power semiconductors are bridged by the internal bypass relays. In this operating mode, the potentiometer setting of the starting time only determines the steepness of the initial ramp function.

After opening of the start/stop-contact, the trigger angle is continuously increased via a ramp-function, and, as a result, the motor voltage is decreased. The motor softly decelerates with the adjusted deceleration time.

Acceleration time, starting voltage and deceleration time can be separately adjusted via potentiometers.

Acceleration or deceleration are effected by closing or opening of the contact on the terminals X1/X2.

The boost function is switched on by bridging the terminals X1/X3. Thus, at the beginning of the soft start, an increased starting voltage is applied to the motor for a period of 0.5s.

The power supply to the control electronics is effected via the power section. On request, the power supply can also be implemented via an external power supply unit (24V min. 150mA DC).

The devices are suitable for an operation of 3-phase motors in star or delta connection. Interconnection of motors in a so-called $\sqrt{3}$ -connection is possible as well.

For $\sqrt{3}$ -connection, it is necessary to use a main contactor K1, since one motor winding lies directly between two phases.

4. Usage to the intended purpose

The devices of the VersiStart II-series are electrical equipment that is used in industrial electrical power installations. They are designed for application in machines, in order to reduce the starting torque and starting current peaks as well as the tripping torque of drives with three-phase induction motors.

Typical Applikations

- door and gate drives
- pumps, ventilators, fans
- conveying systems
- packaging machines
- transport systems, assembly lines
- machine applications

5. EC Declaration of Conformity

EC Declaration of Conformity

The manufacturer / company placing the product on the market
(authorized representatives of the manufacturer / companies placing the product on the market
that are established within the Community)

Name / Address: Peter Electronic GmbH & Co.KG
Bruckäcker 9
92348 Berg
Germany

hereby declares that the following product (device, component, unit) in the version as supplied

Product designation: **Softstarter**
Serien / type designation: VS II 230/400 - 50...75
Article group: 257...
Year of manufacture: 2006

complies with the provisions of the following EC-directives:

2004/108/EG concerning Electromagnetic compatibility and **2006/95/EG** concerning Electrical equipment designed for use within certain voltage limits

The following harmonized standards have been applied:

EN 60947-1: 2008	Low-voltage switchgear and controlgear General rules	EN 60947-4-2: 2007	Low-voltage switchgear and controlgear Contactors and motor-starters - AC semiconductor motor controllers and starters
------------------	---	--------------------	---

This EC Declaration of Conformity is no longer valid, if the products is modified or changed
without our agreement.

This declaration is issued under the sole responsibility of the signatory.

Berg, 05.08.2009
(place, date)

Dr. Thomas Stiller, Managing Director
(signatory and function of the signatory)

(signature)

6. Block diagram

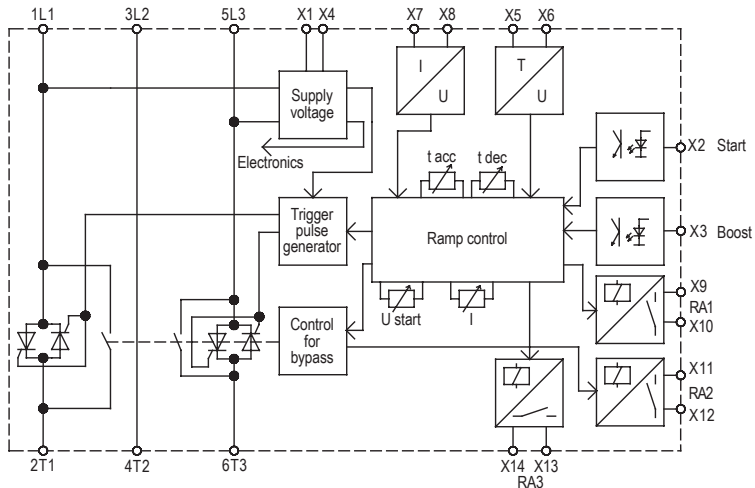

7. Commissioning

The device is to be put into operation in 3 steps:

1. Mounting
2. Connection and
3. Parameter setting

7.1 Mounting instructions



Caution: Danger to life through electric shock!

The following conditions are to be complied with in order to ensure a safe and reliable operation of the VersiStart II.

1. The device series VersiStart II is to be used under conditions of the overvoltage category III.
2. Make sure that pollution degree 2 or better, in accordance with IEC664, is complied with.
3. The device has to be installed into a housing (min. degree of protection: IP54).
4. The device must be operated without being exposed to contamination by water, oil, carbon deposits, dust, etc..

Place the device vertically on a perpendicular mounting plate with the motor terminals pointing downwards. The device is to be mounted with 4 screws (M5) onto a mounting plate. Make sure that no additional heat sources such as equipment with high heat loss, heating resistors or the like are arranged beneath the device; the distance between device and cable duct must be sufficiently large.

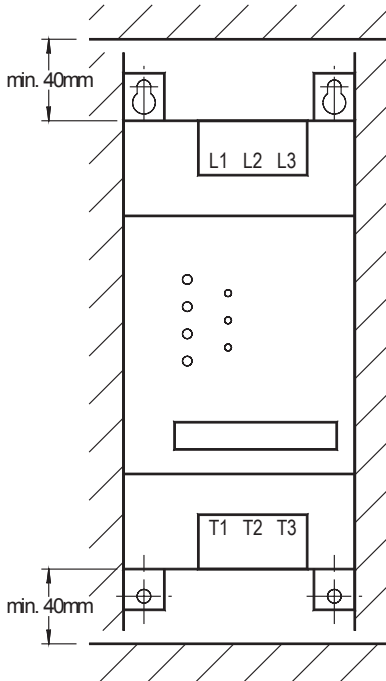

Figure 1



Warning:

To avoid heat concentrations, a distance of at least 40mm is to be kept between cable duct and device.

7.2 Connection

Power section (see also connection diagram)

Terminal 1L1:	Mains voltage L1
Terminal 3L2:	Mains voltage L2
Terminal 5L3:	Mains voltage L3
Earth connection 	PE
Terminal 2T1:	Motor terminal U
Terminal 4T2:	Motor terminal V
Terminal 6T3:	Motor terminal W

Control section

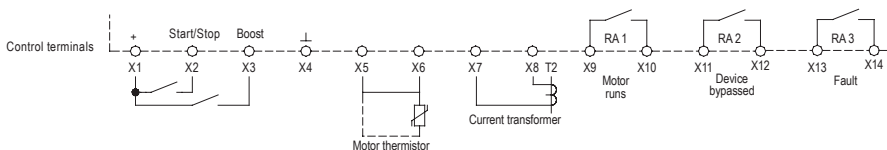

The input resistance of the control inputs is 10kOhm. To control them, it is necessary to use switching contacts enabling reliable switching of the lower control currents (e.g., AgNi+Au)!

If the contact on the terminals X1 and X2 is closed, the motor accelerates with the adjusted acceleration time ramp. When the contact is open, the motor decelerates with the adjusted deceleration time ramp.

Warning:



We recommend to operate the device with the current transformer included in the delivery package, in order to protect the soft starter against destruction caused by too high starting currents (please see Chapter 7.5 Page 11).

Caution: Danger to life through electric shock!



The motor is **not** physically separated from the mains.

Alternatively, the device can also be controlled with d.c. voltage.

If only soft starts are required, VersiStart II may also be controlled via the main contactor. For this purpose, the terminals X1 and X2 have to be bridged.

7.3 Adjusting the control type

The VersiStart II device series can be operated by two control types:

1. Control with a switching contact or switching transistor between terminal X1 and X2.
2. Control by d.c. voltage 10 ... 24VDC between terminals X2 and X4.

Control supply voltage U_S only in the case of wide-voltage devices (option B)

Between the terminals X1 (+) and X4 (⊥) an auxiliary voltage of 24VDC $\pm 10\%$ /150mA is to be injected.

7.4 Parameter settings

On the front panel there are 4 potentiometers by means of which the following settings can be made.

Parameter	Poti	Setting range
Acceleration time	t_{acc}	Acceleration time adjustable from 0,5...10sec
Starting voltage	U_{Start}	40...80% of rated voltage
Deceleration time	t_{dec}	adjustable from 0,5...10sec
Starting current	I	200 ... 500% rated current (only with external current transformer)

Default setting of potentiometers:

Potentiometer	t_{acc}	(acceler. time)	= mid-position
Potentiometer	U_{Start}	(starting voltage)	= left stop
Potentiometer	t_{dec}	(deceler. time)	= left stop
Potentiometer	I	(starting current / voltage ramp)	= left stop

Adjusting soft start

To adjust an optimum starting behavior, you should carry out a test run. Contrary to the default settings, you should make the following basic potentiometer-settings.

Fans, roller tracks, conveyor belts, etc.	t_{acc} 50%, U_{Start} 0%, t_{dec} 0%
Centrifuges, conveyor screws, mixers, compressors, etc.	t_{acc} 50%, U_{Start} 50%, t_{dec} 50%
Pressure pumps, etc.	t_{acc} 50%, U_{Start} 50%, t_{dec} 50%

Switch on the supply voltage and start acceleration. Watch the starting behavior and adapt the appropriate parameters to your drive. At any rate, the starting voltage should be adjusted with the potentiometer U_{Start} so that the motor starts immediately. At the same time, unnecessary humming with the motor being at rest is to be avoided.

The potentiometer t_{acc} is to be adjusted so that the requested acceleration time or starting characteristics is achieved. The acceleration time should always be chosen as short as possible, in order to keep the thermal stress acting on device and motor as small as possible. This leads to short times until the bypass relays pull in and ensures good acceleration characteristics while the power semiconductors and motor are less heated. This is of special importance in the case of high-inertia starting or high switching frequencies. The acceleration time, however, has to be adjusted so that the motor reaches nominal speed before the internal bypass relays close.



Warning:

If the adjusted acceleration time is too short, the internal bypass relays close **before** the motor has reached nominal speed. This can cause damage to the bypass relays.

Adjusting soft stop

With the potentiometer t_{\sim} , the deceleration time can be adjusted and thus the deceleration behaviour of the drive determined. Usually, this function is selected only for pressure pump drives or for drives coming to a standstill within a very short period of time. Thereby, a prolongation of the deceleration time is achieved and pressure and/or torque surges are avoided.

Note: Soft stop is only useful for pump drives or applications in the case of which the drive comes to a stop immediately after switch off. In the case of drives driving high-inertia loads, soft stop is not sensible.

Note: To enable soft stop, the VersiStart II, during the deceleration phase, has to be supplied with power from the supply mains.

In the case of these devices, the cut-off voltage is factory-set to 70%.

The potentiometer t_{\sim} is to be adjusted so that the requested deceleration time or deceleration characteristic is reached.



Caution: Danger to life through electric shock!

Even if the motor is at rest, it is **not** physically separated from the mains.



Warning!

Make sure that the specified switching frequency is not exceeded!

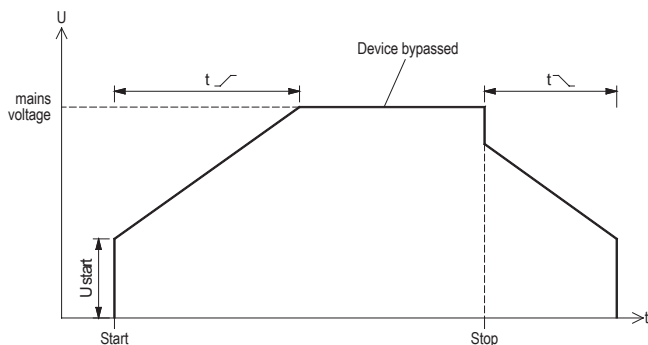

Diagram 1

7.5 Current-controlled start

With the VS II 50...75 devices, it is possible to realize current-controlled starts. For this purpose, an external current transformer has to be connected to the control terminals X7/X8. The transformer suitable for the particular device can be taken from the Technical Data and is to be ordered separately.

The motor lead T2 has to be led through the transformer, see figure 2. With the „I“ potentiometer, the maximum starting current can be adjusted to a value between 200% and 500% of the rated device current. The following diagram 2 shows the function of the adjustment potentiometers. The potentiometer t_{ramp} adjusts the steepness of the voltage ramp to the point where the current-limiting threshold is reached. Should the motor not reach nominal speed within a certain time, the device goes into fault condition and cuts off the motor voltage. The time elapsing until this cut-off point is determined by the performance of the thyristor modules and varies depending on the adjusted starting current „I“ (see diagram 3).

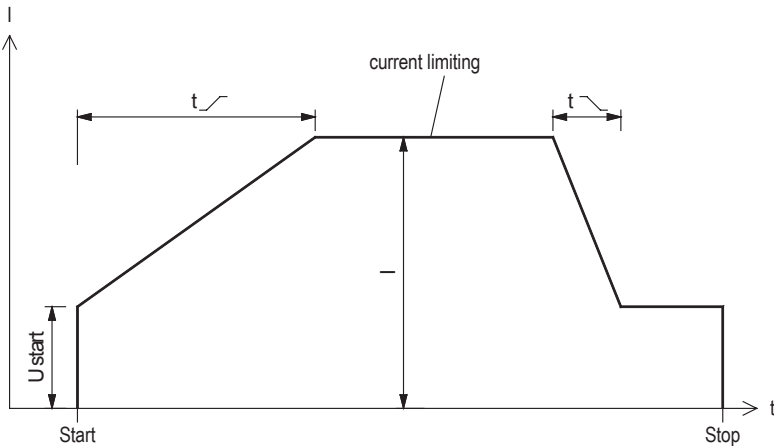

Diagram 2

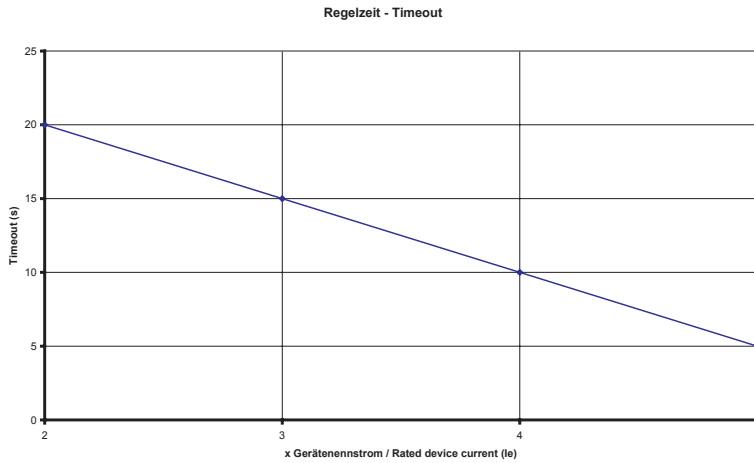

Diagram 3



Figure 2

7.6 Starting frequency

It must be possible for the device or rather the power semiconductors to cool off sufficiently between two starts.

If starts are carried out in too quick succession, there is the danger of thermally overloading and thus destroying the power semiconductors. In this case, the thermal monitoring function of the heat sink will not respond, as it requires some time until the heat loss of the power semiconductors is dissipated into the heat sink. So, if the time interval between starts is too short, the heat sink monitoring function is not able to keep up with the temperature rise of the semiconductors.

Operating the device for a long time in bypassed condition also will cause the power semiconductors to cool off. Starting from a given starting time and starting current, it is possible with the diagrams under section 8.2 to determine the maximum starting frequency per hour. With this value, the required cooling time can be determined.



Warning:

If the time interval between starts is too short, there is the danger of damaging or destroying the power semiconductors.

7.7 Devices with motor-PTC input

In the case of these devices, it is possible to connect a motor-PTC for motor temperature monitoring. The sensor lines of the motor-PTC are to be connected to the terminals X5 and X6 (⊥).

If the motor temperature exceeds the switching threshold, the motor PTC triggers a fault. The soft starter switches the motor off and is interlocked in fault mode. The fault is signalized by the yellow LED repeatedly flashing two times and by an opening of the relay contact between the terminals X13 and X14.

Let the motor cool down, identify the root cause and remove the cause of the intense heating up of the motor.

Attention!

To avoid EMI couplings into the electronics and their disturbances they involve, it is not allowed to use free, unshielded strands in the motor cable for connecting the temperature sensor to the soft starter.

The temperature sensor should be connected with the soft starter by a separate, and preferably, shielded cable. The line ends are to be neatly terminated and unshielded lines must be kept as short as possible.

The sensor cable is, as far as possible, to be laid separately from the power cables in separate cable ducts. If crossings of power cables and control cables are inevitable, they should be arranged at an angle of 90°.

8. LED indicators

On the device front panel there are 3 light-emitting diodes indicating the following operational states.

LED	Operational status
Green	Device is connected to mains voltage
Yellow	Start completed, device bypassed
Yellow - flashing with increasing or decreasing frequency	Soft start / Soft stop
Red, yellow - flashing with constant frequency	Fault, the flashing frequency shows the type of fault

On the control terminals X9 / X10 (RA 1), X11 / X12 (RA 2) and X13 / X14 (RA 3) three signaling relays are available which signal the following operational states:

RA 1 **Motor runs.**

With the beginning of the soft start, the signaling contact RA 1 is closed. At the end of the soft stop it is opened. With this contact, it is possible to control, for instance, a motor contactor.

RA 2 **Device bypassed.**

When the start-up ramp is over and the motor is supplied with nominal voltage, the bypass relays are closed.

RA 3 **Fault.**

Under normal operating conditions the signaling contact RA 3 is closed, it only opens if a fault occurs.

9. Fault

The device series VersiStart II monitors various fault conditions. If a fault is detected, the device signals the fault with the red LED and with flashing of the yellow LED (flashing at constant frequency). In the case of a fault, the signaling relay RA 3 is opened. The various fault conditions are indicated via different flashing frequencies of the yellow LED.

9.1 Fault description

Yellow LED flashing x-times with a short pause	Fault number	Operational status
1x	0	Voltage of power supply to the electronics is too low
2x	1	Heat sink temperature too high/device thermally overloaded (please see also Point 7.6); motor temperature too high
3x	2	Current controll timeout
4x	3	Phase failure 1
5x	4	Phase failure 2
6x	5	Phase failure 3
7x	6	Frequency failure
8x	7	Trigger failure in phase 1
10x	8	Trigger failure in phase 3
11x	9	Mains or motor circuit defective

9.2 Fault remedy

In case of a fault, please proceed as follows:

- Fault 0: Voltage of power supply to the electronics is too low. Check mains voltage on L1, L2, L3, or check external auxiliary voltage.
- Fault 1: Check the frequency of starts and the starting current and also observe the max. ambient temperature. Give the device and/or the motor enough time between starts to cool down. The heat dissipation can be improved by forced cooling, e.g., by means of a fan mounted underneath the device or by using a motor with separately driven fan.
- Fault 2: The motor does not reach final speed with the adjusted maximum starting current. Increase the value of the starting current with the „I“ potentiometer.
- Fault 3: Fault in phase L1 or motor line T1. Check fusing and wiring.
- Fault 4: Fault in phase L2 or motor line T2. Check fusing and wiring.
- Fault 5: Fault in phase L3 or motor line T3. Check fusing and wiring.
- Fault 6: Incorrect mains frequency or unbalanced mains.
- Fault 7: Trigger failure in device phase 1. Check motor wiring or return defective thyristor module device to the producer in order to have it checked.
- Fault 8: Trigger failure in device phase 3. Check motor wiring or return defective thyristor module device to the producer in order to have it checked.
- Fault 9: Mains fault:
The fuses are defective, or failure in the mains- or motor wiring.
Check fuses and wiring.

9.3 Resetting of faults

To reset a device failure, it is necessary to disconnect the device from the supply voltage. After the cause of the fault has been remedied by trained expert personnel, the supply voltage can be reconnected. The device works again under normal service conditions.

Devices with option B (wide-voltage-range power section) must be reset by disconnect the control supply voltage U_S on the terminals X1 and X4.

10. Technical data (standard) *

Type designation VersiStart	VS II 400-50	VS II 400-65	VS II 400-75
Mains / motor voltage acc. to DIN EN 50160 (IEC 38)	400V ±10% 50/60Hz		
Control supply voltage U _S only in the case of option „B“	24VDC ±10%/150mA		
max. Motor rating at 380/415V (rated power)	25kW	30kW	37kW
Rated device current (I _e)	50A	65A	75A
max. Power dissipation - in operation related to the max. frequency of starts - in standby	30W 10W		
min. Motor load	20% of the device rated current		
Acceleration time	0,5 ... 10s		
Starting voltage	40 ... 80% of rated voltage		
Deceleration time	0,5 ... 10s		
Starting current range in the case of current-controlled start	200% - 500% of the device rated current		
Restart time	200ms		
max. Switching frequency at 3x I _N and 5s	35/h	25/h	20/h
Cross-sect. area for connection: Control terminals Power terminals	0,2-2,5mm ² /24-12 AWG solid 1-35mm ² , 18-2 AWG/stranded 1-25mm ² , 18-3 AWG		
Tightening torque (power terminals)	25mm ² = 2,5 Nm 25mm ² = 22 lbs in	35mm ² = 4,5 Nm 35mm ² = 40 lbs in	
I ² t - Power semiconductors	6600A ² s	11200A ² s	25300A ² s
Contact rating of output relays RA 1 / RA 2 / RA 3	3A/250V AC 3A/30V DC		
Input resistance Control inputs	10kOhm		
Surge strength	4kV		
Weight	1,5kg	1,5kg	2,2kg
Special voltages (optional)	230V/480V/wide-voltage range 200-480V and 400-600V with control supply voltage U _S 24VDC±10%/150mA („B“)		
Recommended current transfor- mer, order number	56600.00001		56600.00002

* For special voltages please see our supplement.

10.1 Environmental conditions

Storage temperature	-25 ... 70°C
Ambient temperature	0 ... 45°C up to an installation altitude of 1000m, not exposed to moisture condensation
Power reduction ¹⁾	above 45°C - 2% per 1°C up to max. 60°C and altitudes above 1000m -2% per 100m
Degree of protection	IP 20
Environment	Overvoltage categ. III (TT / TN-systems), pollution degree 2
Installation class	3

¹⁾ The reductions refer to rated power output.

11. Dimensioning rules

11.1 Dimensioning of pre-fuses

Pre-fuses F can be dimensioned according to the following instructions.

Basically, two types of fuse protection are available for the user.

1. Fusing according to allocation type „1“, DIN EN 60947-4-2.
After a short circuit, the VersiStart II device is allowed to be inoperative and repair work is possible.
2. Fusing according to allocation type „2“, DIN EN 60947-4-2.
After a short circuit, the device must be suitable for further use. However, there is the danger that the contacts of the bypass or braking relays weld. Therefore, if possible, these contacts are to be checked prior to reconnecting these contacts to the mains supply. If this check cannot be carried out by the user, the device has to be returned to the producer in order to have it checked.

The following dimensioning information refers to the below operating conditions:

- Use of standard asynchronous motors
- Standard acceleration and/or deceleration times
- Switching frequencies not exceeding the values specified in the data sheet

Fusing according to allocation type „1“

As pre-fuses we recommend to use line protection fuses (utilization category gL) or automatic circuit-breakers with type K tripping characteristic. In the case of automatic circuit-breakers the tripping characteristic of the type series is to be taken into account. With $2x I_n$ the tripping time should be at least 20s (I_1).

The fuse values are to be determined by taking the conductor cross-sectional area of the wiring into account. Depending on the rated motor current, the maximally occurring starting current (normally up to the 5-fold rated device current) and the starting frequency, the wiring cross-sectional area is to be determined. Table 1 shows the values for numerous applications, i.e., with a 3-fold nominal current as mean starting current and a max. starting time of 10s. In the case of parameter values exceeding these values, it may be necessary to adapt the fuse value accordingly.

Note: Wiring cross-sectional area according to DIN VDE 0100-430,
DIN EN 57100-430.

Rated device current (techn. data)	Device type	Fuse value in the case of allocation type 1	Starting frequencies Starts / h
50A	VS II ...-50	100A	35
65A	VS II ...-65	125A	25
75A	VS II ...-75	125A	30

Table 1

Fusing according to allocation type „2“:

The power semiconductors are to be protected by fuses of the utilization class gR (semiconductor protection fuses, high-speed fuses). However, since these fuses do not ensure line protection, it is necessary to use additionally line protection fuses (utilization category gL).

To protect the semiconductors it is necessary to select gR-fuses featuring cutoff- I^2t -values which are approx. 10-15% below the I^2t -value of the power semiconductor (see technical data). In this connection, the fuse rating of the selected fuse should not be smaller than the starting current to be expected.

Notes:

1. Advanced control does not prescribe the use of semiconductor protection fuses. However, for some UL- or CSA-listed devices there are exceptions which are indicated in the relevant commissioning instructions.
2. On the basis of the I^2t -value of the power semiconductors, the starting time and possibly the max. starting current, the fuse supplier is able to select a suitable type. Due to the great variety of producers, sizes and types, Advanced Control does not recommend any particular fuses.
3. If the value of the fuse or the cutoff- I^2t -value is selected too small, it may happen that the semiconductor fuse reacts during the starting phase or during deceleration.

11.2 Determining the permissible starting frequency

The starting frequency depends on the:

1. starting current or the heat loss across the power semiconductors.
2. current carrying capacity and the temperature increase of the power semiconductors.
3. heat sink's capability of absorbing the heat loss and passing the temperature increase on to the environment.

The following diagrams are to assist you in determining the maximum starting frequency per hour, i.e., on the basis of the given maximum starting current and for various starting times.

Should the requested starting frequency not be reached, a different device series has to be chosen.

Example: In a drive, a 22 kW-motor is to be started. A maximum starting current of 180A has been measured. This approximately corresponds to the 4-fold nominal current. The device employed is a VS II 400-50. From the applicable chart it is now possible to read off a max. starting frequency per hour lying between 190 (starting time = 1s) and 19 (starting time = 10S).

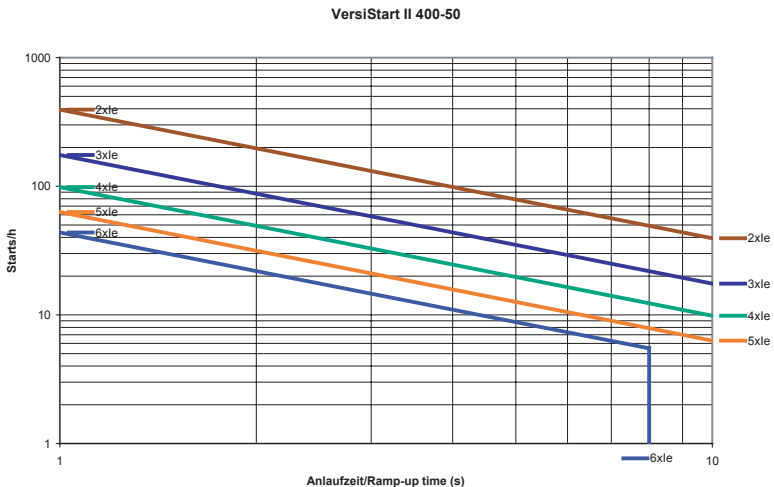

VersiStart II 400-65

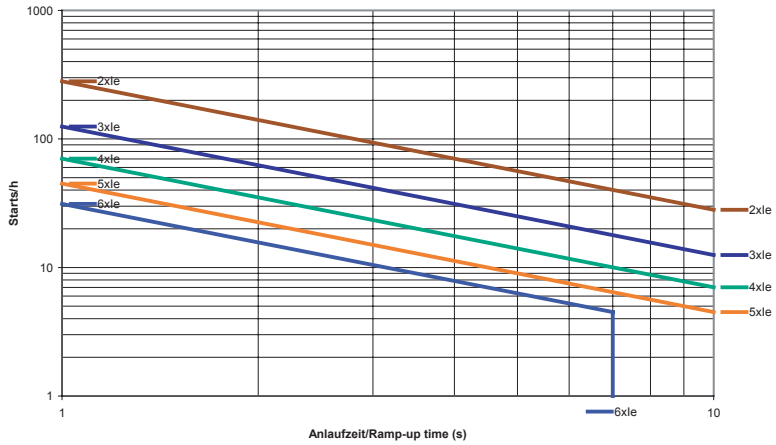

VersiStart II 400-75

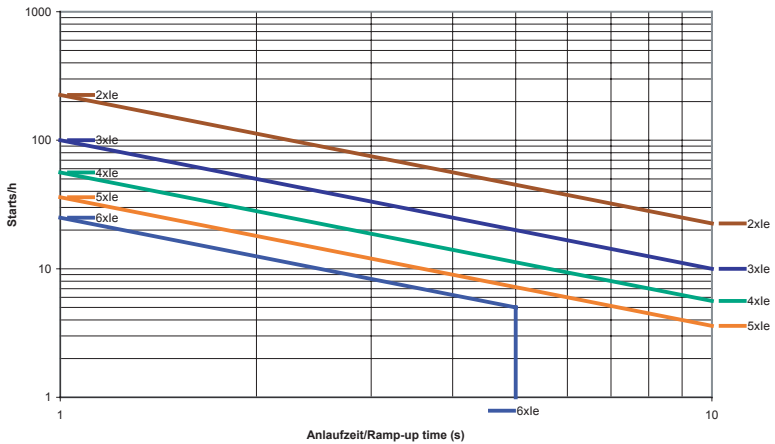

12. Special units

The rated voltage of a device featuring special voltage is indicated on the rating plate. In the case of devices with voltages < 400V it must be ensured that the device rating and the motor rating are not identical. Of prime importance in this connection is the rated device current and the motor current according to rating plate.

12.1 Devices with rated voltage of 230V or 480V

It must be ensured that the mains voltage value indicated on the rating plate is connected to the terminals L1, L2, L3.

Otherwise the devices are to be put into operation like standard devices.

12.2 Devices featuring a wide-voltage-range power section

In the case of wide-voltage-range-capable devices¹⁾ the voltage range for the power supply is 200V ... 400V or 400V...600V. Besides, in order to operate the devices, it is necessary to connect an control supply voltage U_S of 24VDC $\pm 10\%$ /150mA to the terminals X1 (+24V) and X4 (ground).



Caution:

These devices must be reseted by disconnect the auxiliary voltage.

Otherwise the devices are to be put into operation like standard devices.

12.3 Devices featuring special voltage $\geq 500V$

Devices $\geq 500V$ are equipped with power semiconductors featuring higher reverse voltages. These devices are to be connected and put into operation like devices having a wide-voltage-range power section.

13. Installation guidelines

The devices are to be installed into a switchbox or switchgear cabinet according to point 2 and 4. It must be ensured that the switchbox/switchgear cabinet is capable of dissipating the occurring heat loss (see techn. data).

13.1 Connection

The device is to be installed according to the attached connection diagram. For other connections please consult PETER electronic GmbH & Co. KG.

13.1.1 Earthing

The electrical earthing provided ensures a low impedance connection between all metallic surfaces. Apart providing a degree of electrical safety and isolation, the earthing also has the beneficial effect that the flow of RF currents can be directed through the structure of the equipment rather than through sensitive circuits, where it could be disruptive. It is for this reason that it is vitally important to provide separate earth conductors for each part of the installation all connected to a common star point.

¹⁾ with option „B“

13.1.2 Cabling

To avoid EMI couplings into the electronics and the disturbances they involve, it must be ensured that the control cables are laid separately in separate cable ducts and as far as possible away from the power cables. If control cables crossing power cables, they have to be laid at an angle of 90° (Figure 3).

When connection shielded cables make sure that the unshielded cable ends are as short as possible. The large-surface shield bonding must not necessarily be located on the end of the shielding but may also be established in a suitable place - at a distance of some centimetres (Figure 4).

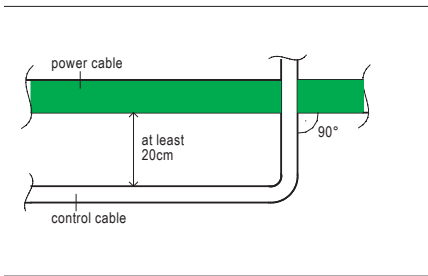

Figure 3

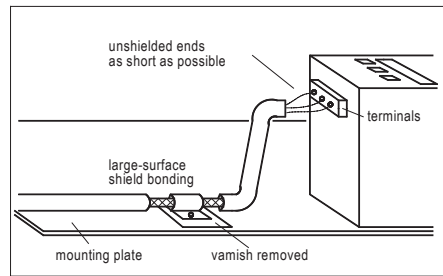

Figure 4



Caution:

The protective conductor connection to the motor must not be laid in shielded motor cables, but is to be separately laid with an appropriate cross-sectional area. The individual earthing systems, power earth, protective earth, digital earth, and analog earth conductors should be laid separately by using a suitable star-point wiring.

Note: Further connection diagrams for special circuit arrangements are available on our homepage at www.advcontrol.eu

Note: Prior to putting the VersiStart II into operation the wiring is to be checked.

13.2 General connection diagram

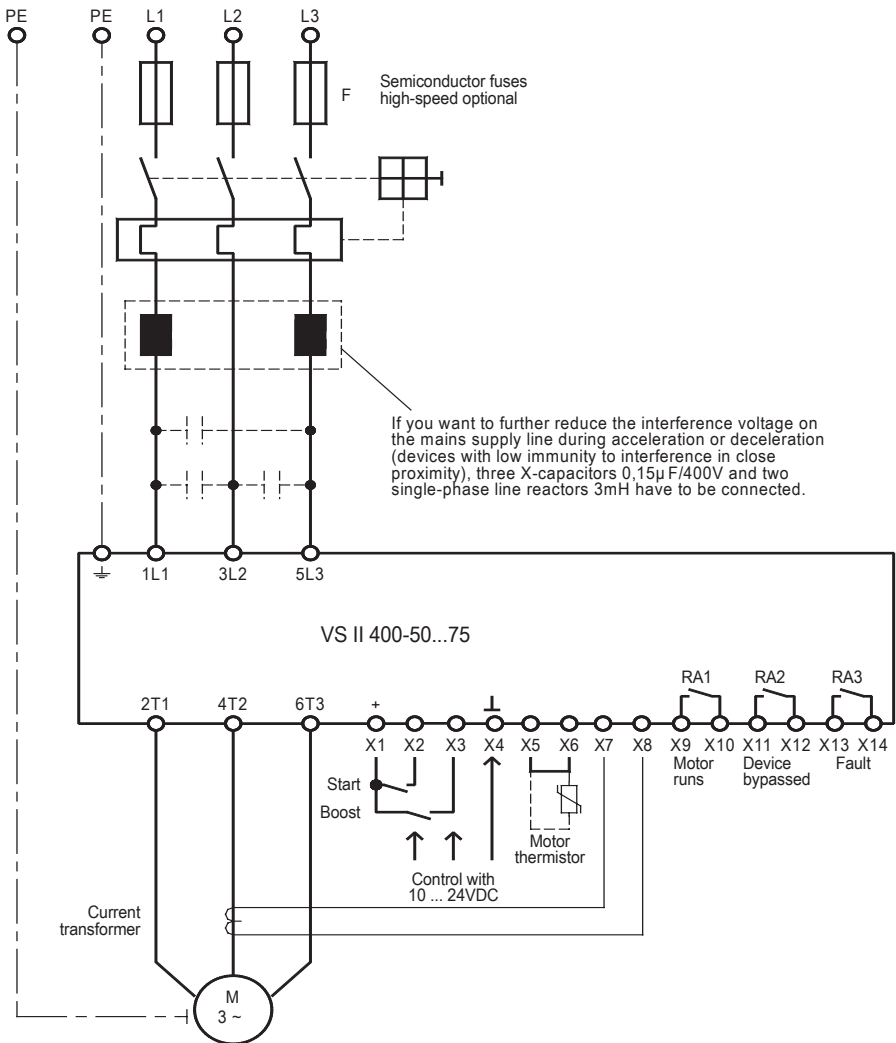

13.3 Typical connections

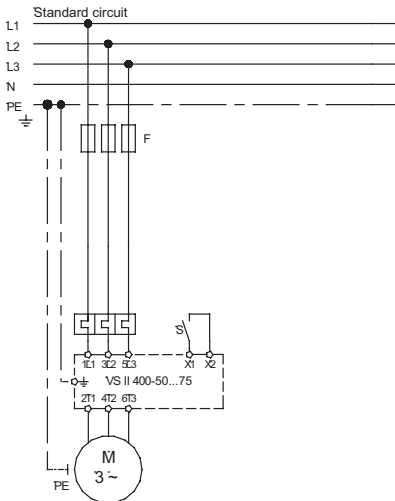

S - closed = acceleration; S - open = deceleration

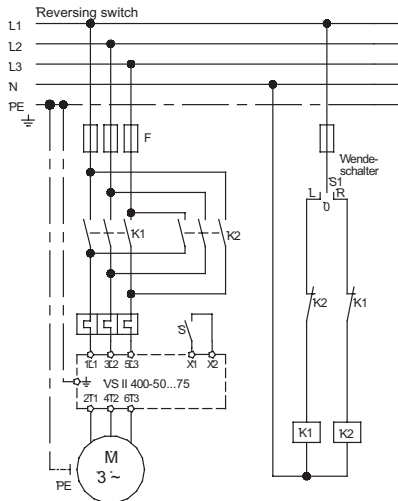

S - closed = acceleration; S - open = deceleration

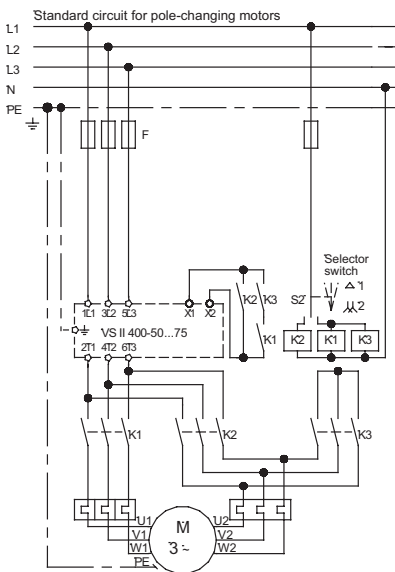

For pole-changing motors turn trimmer t off to 0 (counter-clockwise stop)

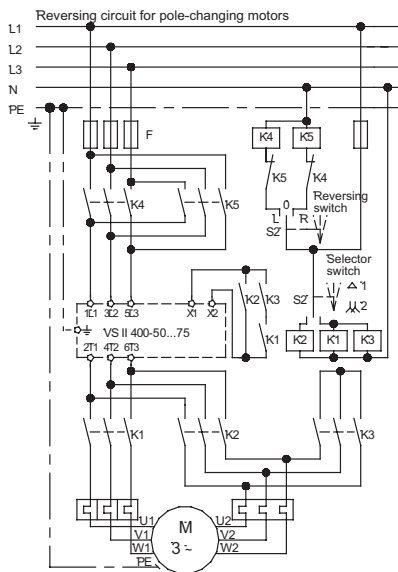

13.4 Connection with motor contactor

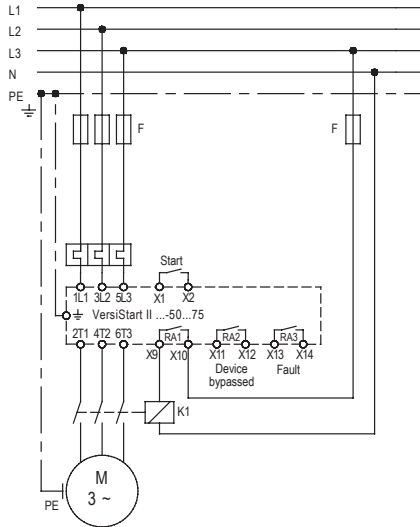

13.5 Motor/Soft start in delta connection

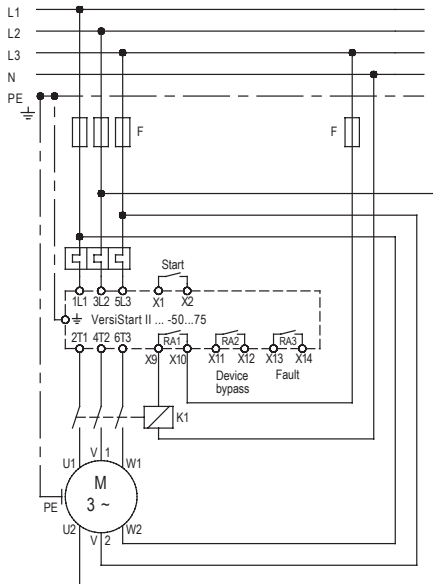

Further connection diagrams are available via the internet at www.advcontrol.eu

13.6 Wide-voltage-range connection

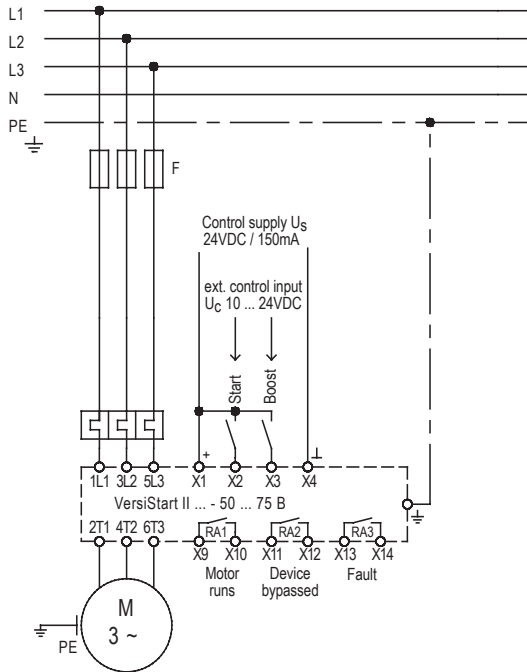

Further connection diagrams are available via the internet at www.advcontrol.eu

14. Dimensions

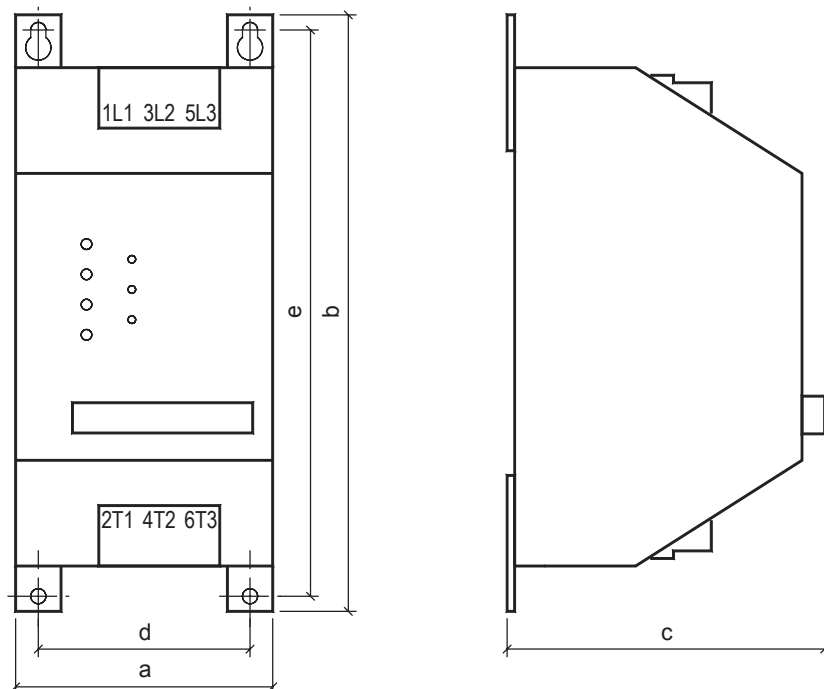

Mounting dimensions	a	b	c	d	e
VS II ...-50...65	103	230	125	86	220
VS II ...-75	103	230	140	80	220

All dimensions indicated in mm.

15. Special units

Please see supplement.



advcontrol.eu

