

**MULTI-LOOP MODULE TYPE  
TEMPERATURE CONTROLLER  
<Event Input/Output Module>**

**TYPE: PUME**

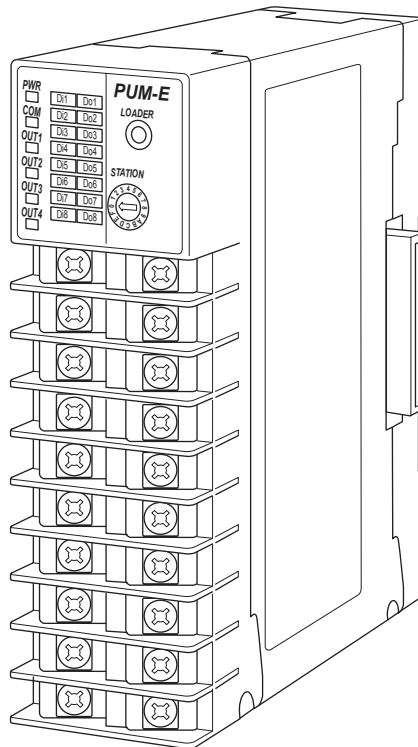





## Please Read First (Safety Warnings)

Please read this section thoroughly before using and observe the mentioned safety warnings fully.

Safety warnings are categorized as "Warning" or "Caution".

 Caution	Improper use of the equipment may result in death or serious injuries.
 Warning	Improper use of the equipment may cause injury to the user or property damage.

## Warning

### Installation and Wiring

- This equipment is intended to be used under the following conditions.

Ambient temperature	-10 to 50 degree C
Ambient humidity	90% RH or below (with no condensation)
Vibration	10 to 70Hz less than 9.8m/s <sup>2</sup> (1G)
Warm-up time	30 min. or more
Installation category	IEC1010-1: class II
Pollution level	IEC1010-1: degree 2

- Between the temperature sensor and the location where the voltage reaches or generates the values described below, secure clearance space and creepage distance as shown in the table below.

If such space cannot be secured, the EN61010 safety compliance may become invalid.

Voltage used or generated by any assemblies	Clearance Space [mm]	Creepage Space [mm]
Up to 50 Vrms or Vdc	0.2	1.2
Up to 100 Vrms or Vdc	0.2	1.4
Up to 150 Vrms or Vdc	0.5	1.6
Up to 300 Vrms or Vdc	1.5	3.0
Above 300 Vrms or Vdc	Please consult our distributor	

- For the above, if voltage exceeds 50Vdc (called danger voltage), basic insulation is required between the earth and all terminals of the equipment.

Note that the insulation class for this equipment is as follows. Before installing, please confirm that the insulation class for equipment meets usage requirements.

Power	DI1 to 4
Loader communication	DI5 to 8
RS-485 communication	DO1 to 4
	DO5 to 8

Functional insulation  
(1000V AC)

Functional insulation  
(500V AC)

- In cases where damage or problems with this equipment may lead to serious accidents, install appropriate external protective circuits.
- To prevent damage and failure of the equipment, provide the rated power voltage.
- To prevent electric shock and equipment failure, do not turn the power ON until all wiring is complete.
- Before turning the power ON, confirm that clearance space has been secured to prevent shock or fire.
- Do not touch the terminal while the machine is ON. Doing so risks shock or equipment errors.
- Never disassemble, convert, modify or repair this equipment. Doing so risks abnormal operation, shock or fire.

### Maintenance

- When installing or removing the equipment, turn the power OFF. Otherwise, shock, operational errors or failures may be caused.
- Periodic maintenance is recommended for continuous and safe use of this equipment.
- Some parts installed on this equipment have a limited life and/or may deteriorate with age.
- The warranty period for this unit (including accessories) is one year, if the product is used properly.

## Caution

### Cautions when Installing

Please avoid installing in the following locations.

- Locations in which the ambient temperature falls outside the range of 0 to 50 degrees C when equipment is in use.
- Locations in which the ambient humidity falls outside the range of 45 to 85% RH when equipment is in use.
- Locations with rapid temperature changes, leading to dew condensation.
- Locations with corrosive gases (especially sulfide gas, ammonia, etc.) or flammable gases.
- Locations with vibration or shock directly.
- Locations in contact with water, oil, chemicals, steam or hot water.  
(If the equipment gets wet, there is a risk of electric shock or fire, so have it inspected by Fuji distributor.)
- Locations with high concentrations of atmospheric dust, salt or iron particles.
- Locations with large inductive interference, resulting in static electricity, magnetic fields or noise.
- Locations in direct sunlight.
- Locations that build up heat from radiant heat sources, etc.

### Cautions when Mounting to Cabinets / DIN Rails

- In case of mounting the temperature controllers to DIN rails, remember to push up the locking tabs to fasten the controllers onto DIN rail.
- To connect controllers, first release all locking tabs. Then, connect controllers and push up all locking tabs. Make sure that all locking tabs are fastened.
- Never fail to turn the power OFF, before detaching the terminal block or removing the main unit from the base part.
- In order to aid heat dissipation, do not block the top and the bottom of the equipment.
- When mounting / dismantling controllers to / from DIN rails, 30mm of clearance above and under the controllers should be provided.

### Cautions for Wiring

- Input signal wire and output signal wire should be separated from each other. And both should be shielded.
- If the output operation frequency is high, selecting a SSR/SSC drive output type is recommended.

[Proportionate cycles]

Relay output: 30 sec. or more

SSR/SSC drive output: 1 sec. or more

- When inductive loads such as magnetic opening/closing equipment, etc. as relay output equipment are connected, use of "Z-trap," manufactured by Fuji Electric Device Technology Co., Ltd., is recommended in order to protect the contacts against opening/closing surges and to ensure long-term use.

Model names: ENE241D-07A

(For 100V power voltage)

ENE471D-07A

(For 200V power voltage)

Attachment position:

Please connect between the relay control output contacts.

(Example)

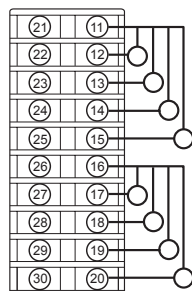

Z-trap connecting diagram

- To comply with CE marking (EMC), we recommend to attach ferrite core to communication cable and power cable.
- For wiring to the terminal block, apply crimp type terminals size M3.  
Use terminal screws in this product only.  
Screw size: M3×7 (with square washer)  
Screw tightening torque: 0.78N·m (8kgf·cm)
- To avoid the influence of inductive noise, input signal wires should be separated from electric power lines or load lines.

### Error Operation

- The alarm function does not work properly when an error occurs unless the settings are made correctly. Always verify its setting before operation.

### Others

- Please do not wipe the equipment with organic solvents such as alcohol or benzene, etc. If wiping is necessary, use a neutral cleaning agent.
- Do not use mobile phones near this equipment (within 50cm). Otherwise a malfunction may result.
- Malfunctions may occur if the equipment is used near a radio, TV, or wireless device.
- This equipment requires approx. 20 seconds before it starts to output.
- Before installing and wiring, take necessary measures for electrostatic discharge (ESD).
- The power supply for this product is 24V DC. Please use the power source of appropriate volume depending on the number of units you connect.

Recommended power source:

Cosel Electronics Co., Ltd. PBA Series

Omron Corporation S8VM Series

# Contents

---

Please Read First (Safety Warnings) .....	3	3.4 Attaching Accessories (Optional) .....	3-11
△Warning .....	3	Attaching Side Connecting Terminal Covers .....	3-11
Installation and Wiring .....	3	Attaching End Plates .....	3-11
Maintenance .....	3	3.5 Mounting with Screws .....	3-12
△Caution .....	3	3.6 Terminal Block Diagram .....	3-13
Cautions when Installing .....	3	Wiring .....	3-13
Cautions when Mounting to Cabinets/DIN Rails .....	4	Wiring for Power Supply/RS-485 .....	3-14
Cautions for Wiring .....	4	<b>4 System Setting .....</b>	<b>4-1</b>
Error Operation .....	4	4.1 Operating Method .....	4-3
Others .....	4	Operating Method .....	4-3
<b>1 Overview .....</b>	<b>1-1</b>	DO Latch Release .....	4-4
1.1 Overview .....	1-3	DI Latch Release .....	4-5
1.2 Model Code .....	1-4	RUN/Standby Switch .....	4-5
Event Input/Output Module .....	1-4	4.2 Input Setting .....	4-7
Accessories .....	1-4	Input Setting .....	4-7
1.3 Part Names and Functions .....	1-5	DI Input Option Setting .....	4-8
External View .....	1-5	Input NOT Setting .....	4-10
Front Terminal Block .....	1-6	Input AND Setting .....	4-11
Base Part .....	1-7	Input OR Setting .....	4-13
<b>2 System Configuration Example ...</b>	<b>2-1</b>	4.3 Output Setting .....	4-15
2.1 System Configuration Example .....	2-3	Output Setting .....	4-15
System Configuration Using Event		Output Types .....	4-17
Input/Output Module Controllers .....	2-3	Output Source .....	4-18
<b>3 Installation .....</b>	<b>3-1</b>	Bit Position Specification .....	4-19
3.1 Installation Procedure .....	3-3	DO Output Option .....	4-20
Stand Alone System .....	3-3	Output NOT Setting .....	4-22
Setting of RS-485 Communication		Output AND Setting .....	4-23
Host System .....	3-4	Output OR Setting .....	4-25
3.2 Dimensions .....	3-5	Output Scaling Base and Span Setting .....	4-27
Dimensions .....	3-5	DO Proportional Cycle .....	4-28
3.3 Mounting Controllers .....	3-6	Output Limit .....	4-29
How to Remove Front Terminal		Internal DO Area .....	4-31
Block/Base Part from the Main Unit .....	3-6	Standby Output Set Value .....	4-32
Mounting to DIN Rails .....	3-8	FAULT Output 1 Set Value .....	4-33
Order of Controllers .....	3-10	4.4 Communication Setting .....	4-35
		Communication Setting .....	4-35
		RS-485 Communication Speed Setting	
		and RS-485 Parity Setting .....	4-36

RS-485 Communication Permission Setting .....	4-36
Enhanced Communication Module (PUMC)	
Connection Permission .....	4-37
RS-485 Response Interval Time Setting .....	4-38
4.5 Monitor.....	4-39
Monitor .....	4-39
DO Calculated Result Monitor .....	4-40
DI Calculated Result Monitor .....	4-41
DI Terminal Monitor .....	4-42
System FAULT Status .....	4-43
LED Display and Setting .....	4-44

## **5 Communication ..... 5-1**

5.1 Communication Functions .....	5-3
Connecting to a Programmable Controller .....	5-4
Connecting to a Personal Computer .....	5-4
5.2 Communication Specifications .....	5-5
RS-485 .....	5-5
Loader Interface .....	5-6
5.3 Connection .....	5-7
Assignment of Communication Terminals .....	5-7
Connection with RS-485 .....	5-8
Connection with Loader Interface .....	5-9
5.4 Setting Communication Parameters .....	5-10
Setup Items for RS-485 (PUM Side).....	5-10
Setup Items on Loader Interface (PUM Side) .....	5-11
5.5 Modbus RTU Communication Protocol .....	5-12
Message Composition.....	5-14
Calculating Error Check Code (CRC-16) .....	5-17
Transmission Control Steps .....	5-18
5.6 Command and Transmission Frame Details.....	5-20
Reading Data .....	5-20
Writing Data .....	5-25
5.7 Address Map and Data Format .....	5-29
Operation Parameters .....	5-29
Digital Input Parameters .....	5-30
Digital Output Parameters .....	5-31
Communication Parameters .....	5-34
Configuration Parameters .....	5-34
Monitor Parameters .....	5-34
Internal DO Data Area .....	5-35
Order of Register Numbers .....	5-36

5.8 Sample Program .....	5-39
--------------------------	------

## **6 Troubleshooting ..... 6-1**

6.1 Troubleshooting Procedures .....	6-3
Troubles that May Occur	
when the Loader Software is Connected .....	6-3
Troubles During Operation .....	6-4
Troubles with RS-485 Communication .....	6-6

## **Index**

# 1

# Overview

1.1	Overview .....	1-3
1.2	Model Code .....	1-4
1.3	Part Names and Functions .....	1-5





# 1.1 Overview

PUME is an event input/output module, which digital input/output when connected with a control module.

- PUME is used for a temperature control system made up of module type temperature controller PUM series, to operate control modules by digital input or when logic output from a control module is needed.
- PUME is equipped with 8 points of digital input terminal (DI) and 8 points of digital output (DO) terminals. PUME is also equipped with communication port and supports Modbus RTU.
- Space and labor saving wiring ; with only one unit directly connected to power supply and RS-485, all connected controllers are also connected to them internally via side connectors.

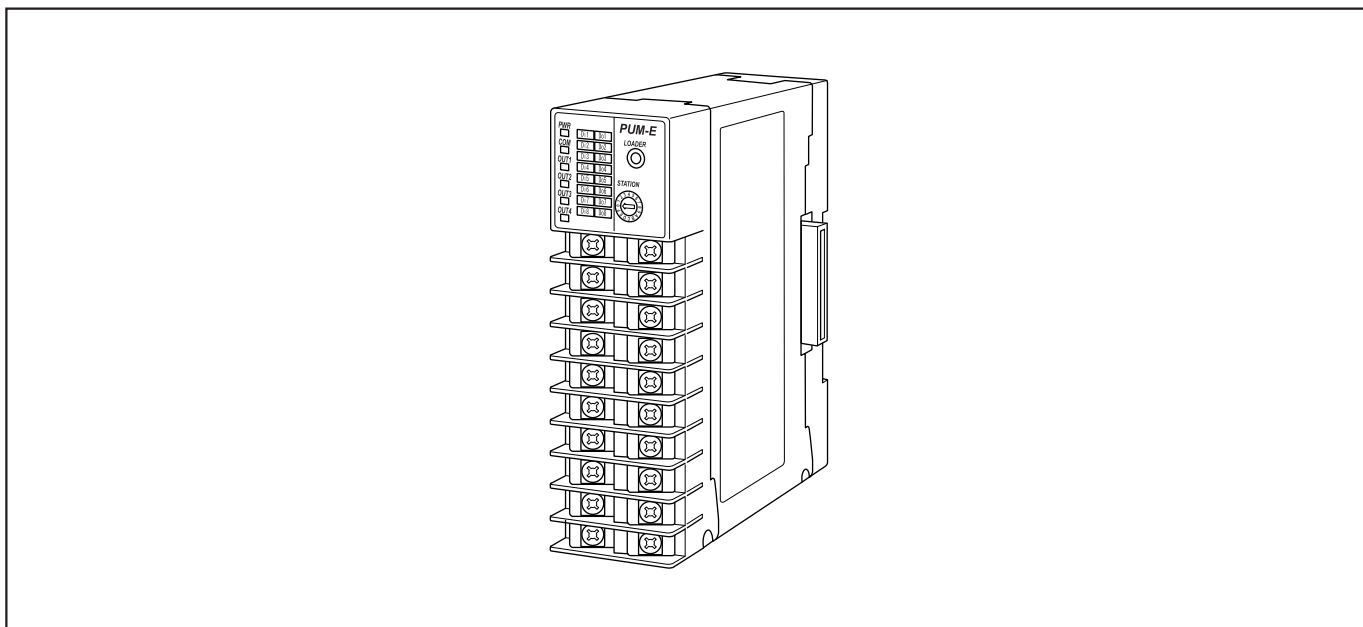

Hereinafter, PUME will be also referred to as “this equipment” or “event input/output module”.

## Confirming accessories

Before using the product, please confirm that all of following accessories are included.

Description	Quantity
Temperature Controller Event Input/Output Module	1 unit
Instruction manual (Installation)	1 copy

# 1.2 Model Code

## Event Input/Output Module

1	2	3	4	5	6	7	8	9	10	
P	U	M			Y	Y	1	-	0	
Description										
Module type										
Event input/output module [DI 8 points / DO 8 points]										
Output type										
Transistor open collector (sink) output										
Relay contact output										
Instruction manual										
A Japanese										
B English										

## Accessories

1	2	3	4	5	6	7	8			
P	U	M	Z	*						
Description										
A 0 1 RS-485 terminating resistance										
A 0 2 DIN rail mounting end plate										
A 0 3 Side connecting terminal cover (right & left 1 set)										
A 0 4 Front face screw terminal cover										
L 0 1 Loader connecting cable (RS-232C)										

# 1.3 Part Names and Functions

## External View

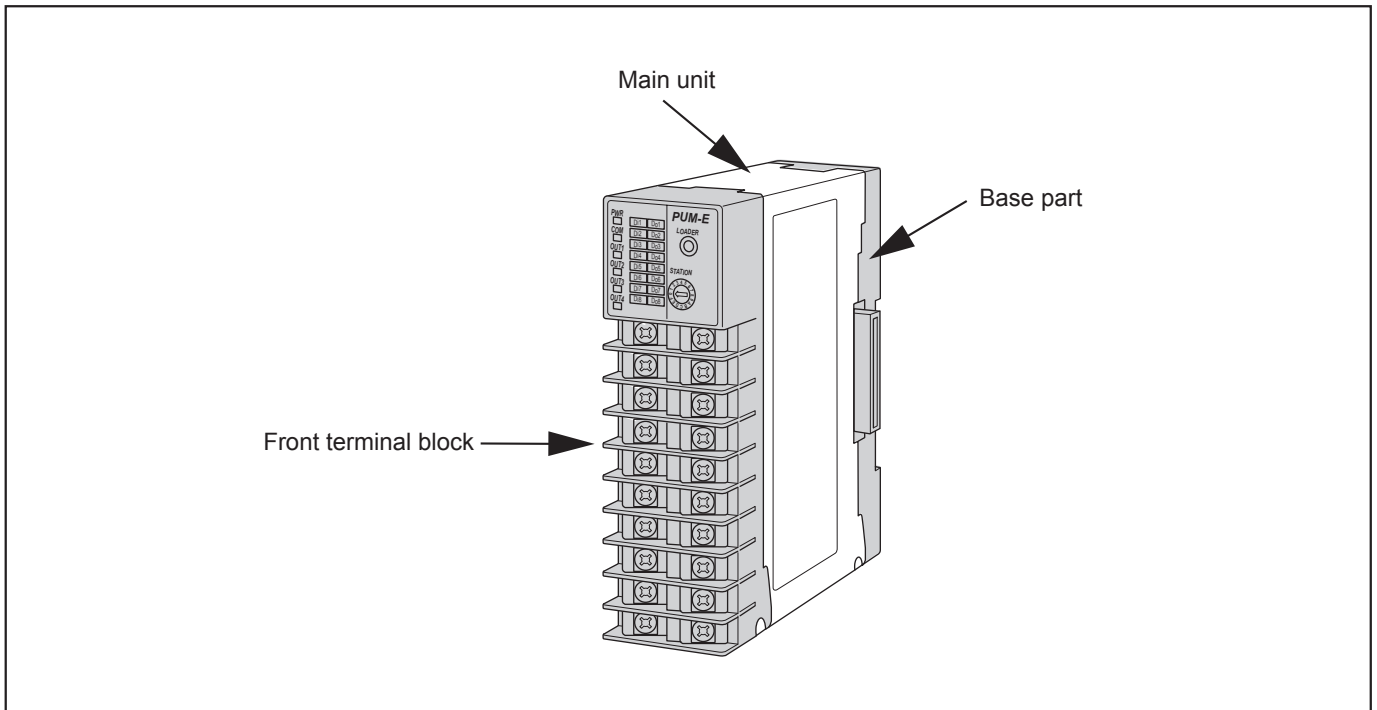

### Front terminal block

The front terminal block consists of loader communication port, station No. configuration switch, and LED indicator lamps.

- The front terminal block can be removed from the main body without tools in seconds.

### Main unit

The main unit of the controller is equipped with event input/output function.

The main unit can be removed from the base part without tools in seconds.

### Base part

The base part incorporates power terminal, RS-485 terminal and lateral connection connectors with a DIN-rail mounting structure.

## Front Terminal Block

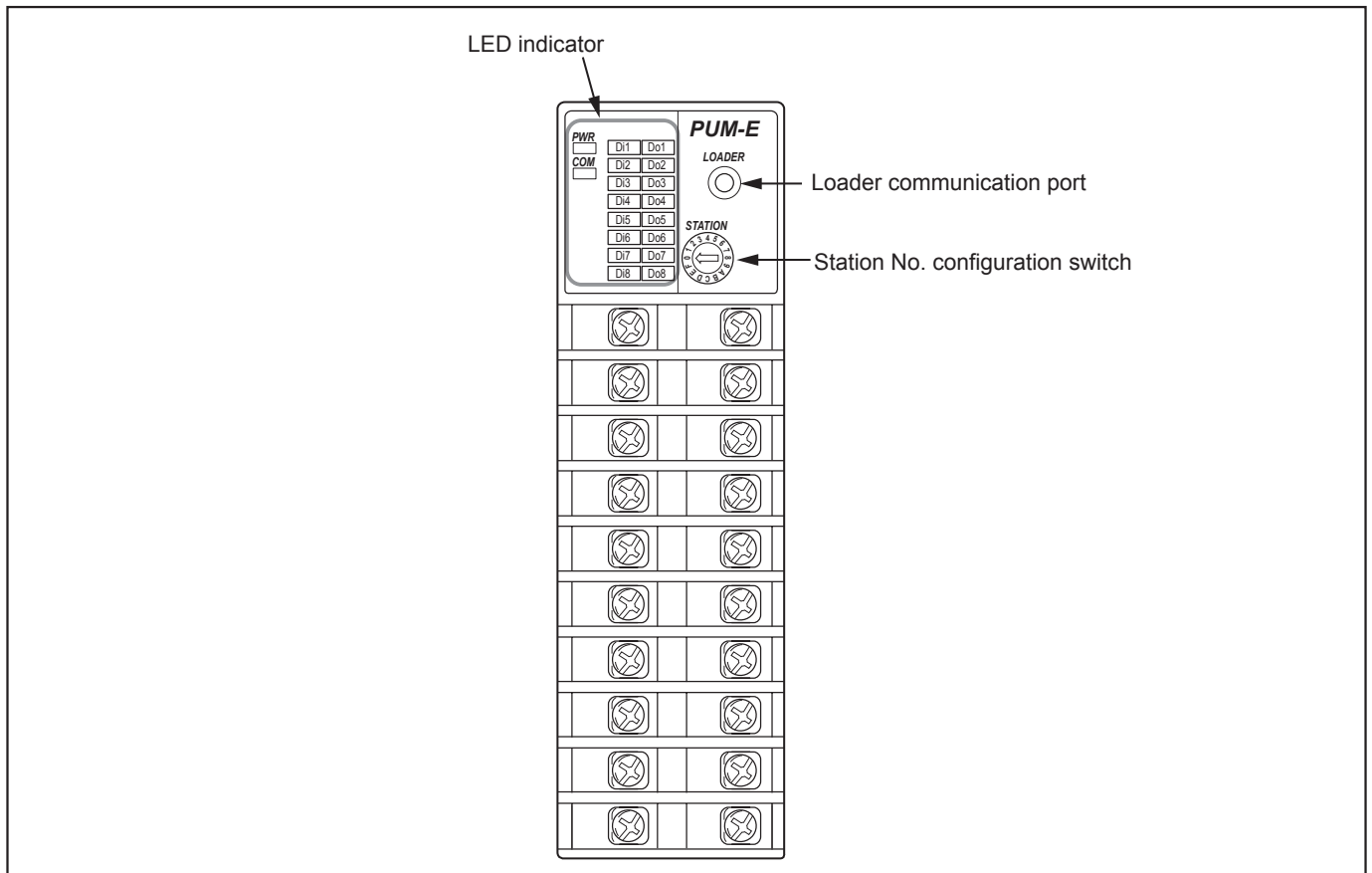

### LED indicator

LED lamps indicate the following operational conditions.

Illuminated LED	GREEN	RED	Orange
PWR	RUN	Error (internal communication FAULT)	—
COM	RS-485 receiving	—	RS-485 transmitting
DI1 to DI8 *	Digital inputting		
DO1 to DO8 *	Digital outputting		

\* Actions to be displayed for COM, can be allocated by parameter.

### Loader communication port

Loader communication port is an interface to connect PUME with a PC with a parameter loader software installed using an optional loader connecting cable.

### Station No. configuration switch

Station No. configuration switch sets the station number of each controller.

The actual station number will be the number set by Station No. configuration switch plus 17.

## Base Part

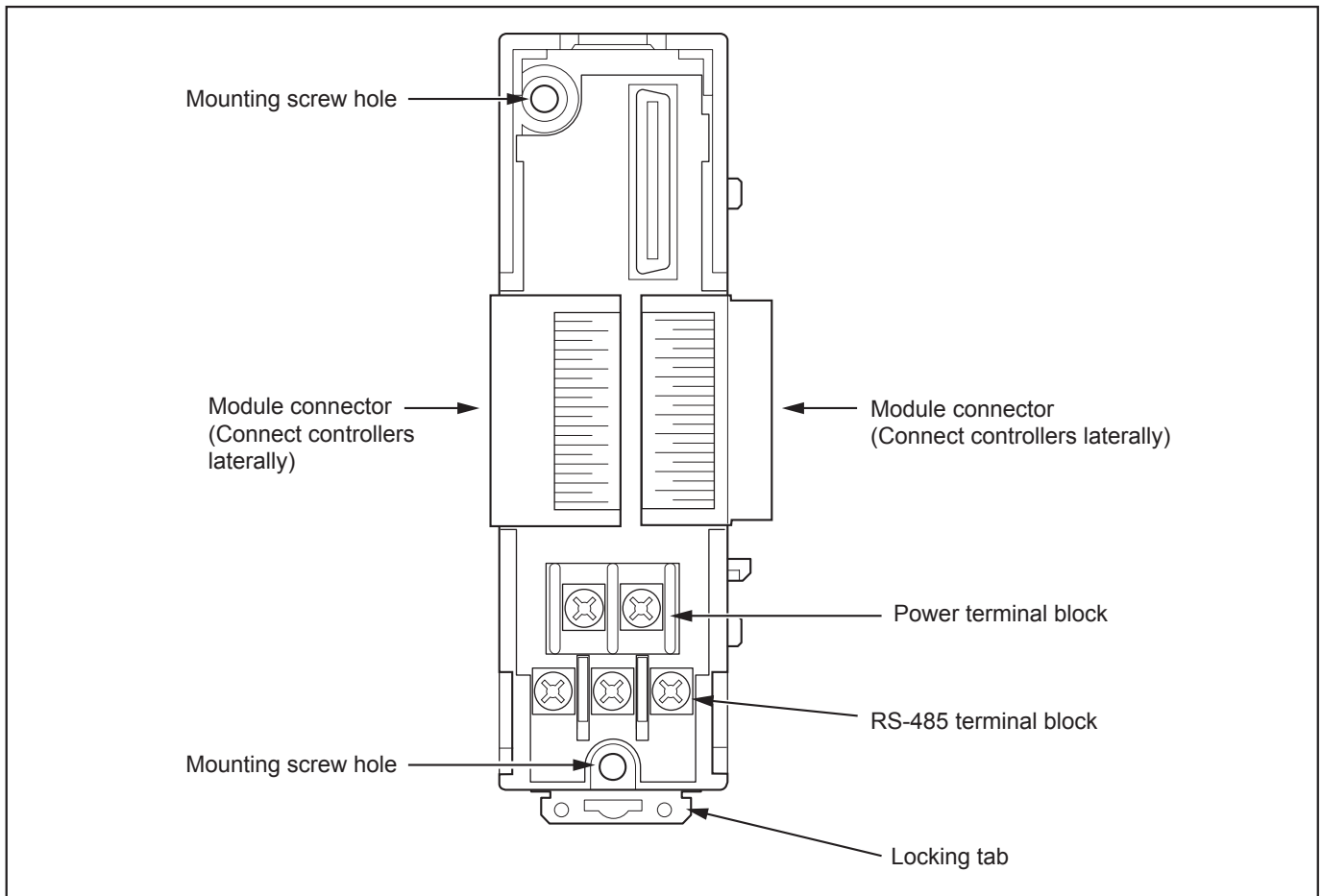

### Module connector

Module connectors connect controllers laterally.

### Power terminal block

Power terminal block connects power supply to PUME.

If any one of connected controllers is directly connected with power supply, power will be provided to all of controllers via side connectors.

### RS-485 terminal block

RS-485 terminal block connects an RS-485 communication cable to perform serial communication with PLC, operation display, and PC, etc.

If any one of connected controllers is directly connected with RS-485, all of controllers will be also connected via side connectors.

### Locking tab

Locking tab fastens a controller onto DIN rail when mounting controllers to a DIN rail. Locking tabs also fasten controllers onto each others.

# 2

## System Configuration Example

### 2.1 System Configuration Example .....2-3



# 2.1 System Configuration Example

The following diagram shows an example of a temperature controller system of multi-loop module type temperature controller PUM series including PUME.

## System Configuration Using Event Input/Output Module Controllers

The following functions are added if event input/output module are included in the system.

- Control module are operated by digital input.
- Event output such as alarm and distributed output are possible.

### Point

- As for digital input (DI), function source module setting is designated on the control module.
- As for digital output (DO), function source module is designated on the event input/output module.

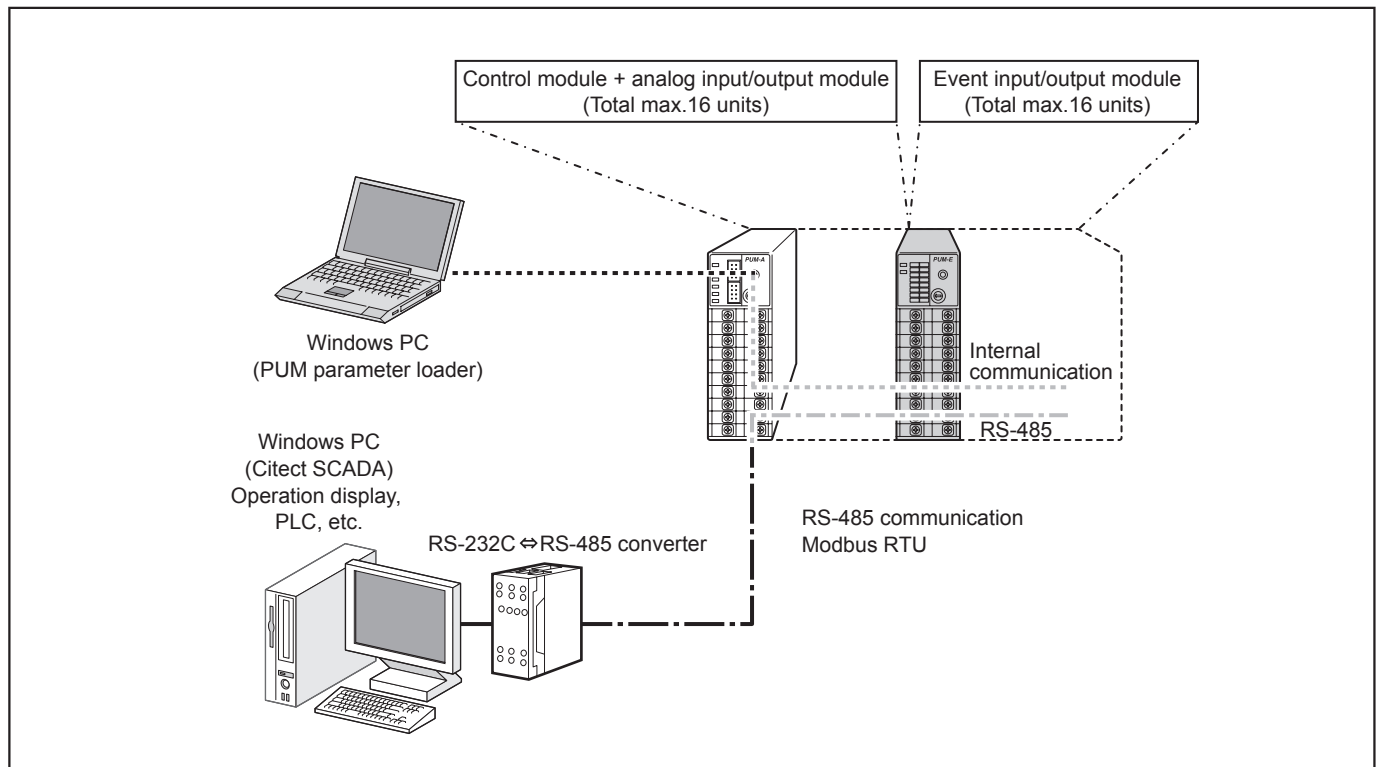



## 2.1 System Configuration Example

---

### Point

- Master/slave setting

Set the leftmost controller of connected controllers as “Master” and the rest of them as “Slave”. Each controller needs to be set as “Master” or “Slave” via loader communication port only one. When connecting a parameter loader software via loader communication port, it is only necessary to connect it with the master controller and the setting for the all of slave controllers can be also done. (If a slave controller is directly connected, the setting for other controllers cannot be done.)

After installation, check whether the controller is “master” or “slave” by LED indicator.

LED indicator	LED lamp condition
PWR indicator of slave module	Green lamp will be illuminated at start up and during operation.

- Station number of control module (1 to 16)

In order to perform communication correctly, setting station number is required. Set the leftmost controller to “1”. Number the rest of controllers consecutively as “2”, “3”, ..... “16”. Make sure that there is no duplicate station number in the same system.

### Note

- Station number of event input/output module (17 to 32)

The station number of event input/output module must start with “17”. Number the rest of controllers consecutively as “18”, “19”, ..... “32”. Make sure that there is no duplicate station number in the same system.

## Basic setting items

In case of this example, the following settings are required.

- Station number setting ▶▶ P1-6
- Master/slave setting ▶▶ See Control module user’s manual
- RS-485 communication setting ▶▶ See Control module user’s manual
- DI function select ▶▶ See Control module user’s manual
- DI master station setting ▶▶ See Control module user’s manual
- Event output setting ▶▶ See Control module user’s manual
- DO master module station number ▶▶ P4-18
- DO master madule channel number ▶▶ P4-18

# 3

## Installation

3.1	Installation Procedure.....	3-3
3.2	Dimensions .....	3-5
3.3	Mounting Controllers .....	3-6
3.4	Attaching Accessories (Optional) .....	3-11
3.5	Mounting with Screws .....	3-12
3.6	Terminal Block Diagram.....	3-13



# 3.1 Installation Procedure

Followings are the procedure of setting for startup via PUM parameter loader software, and setting between host equipment and test operation.

## Stand Alone System

- Control module need station number setting and master/slave setting.
- Setting for all of the connected modules can be done by connecting the master module with a PUM parameter loader software.

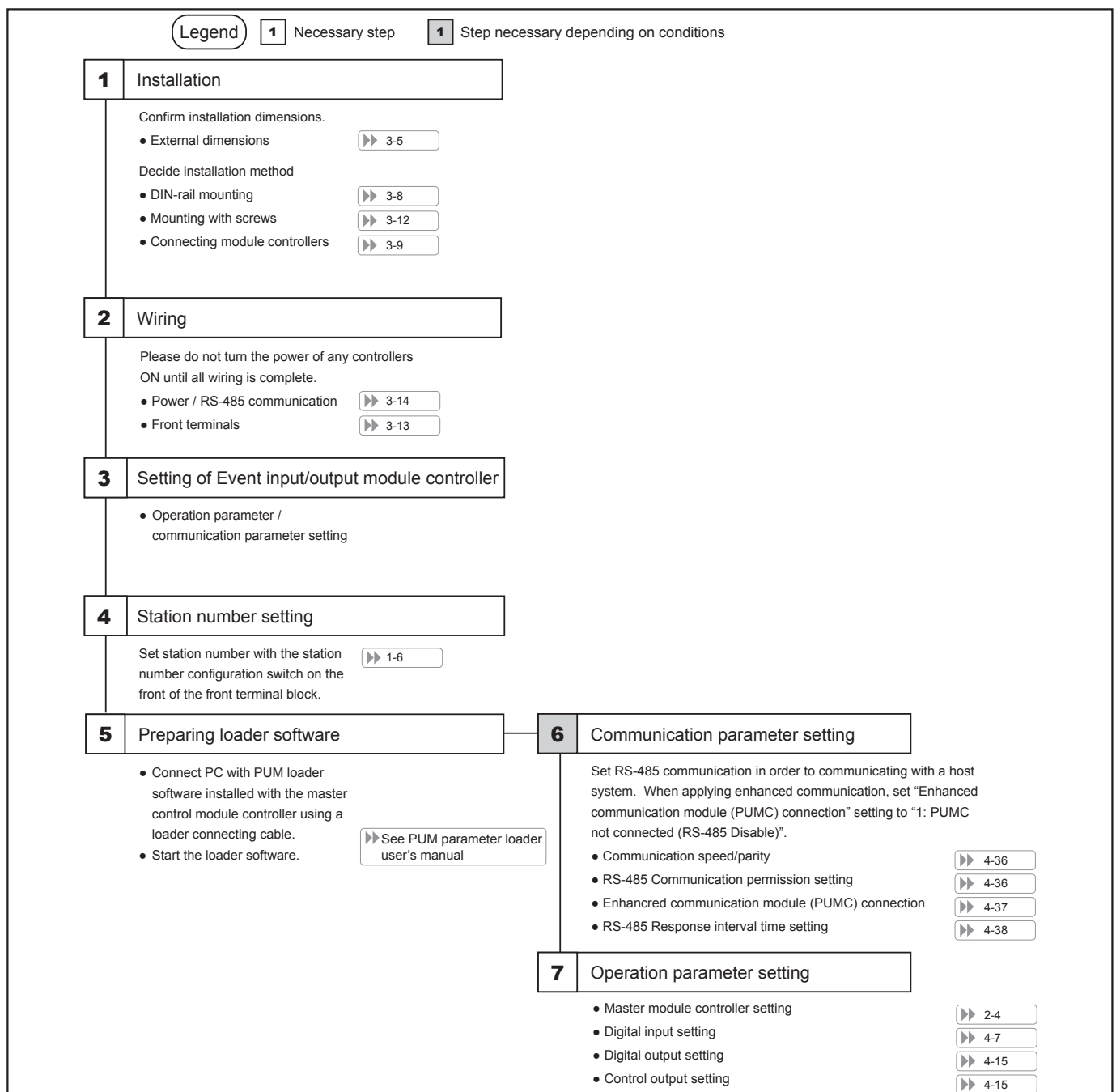

## Setting of RS-485 Communication Host System

- Setting of host equipment and PUM must be the same to perform communication correctly.
- Please do not turn the power of any controllers ON until all wiring is complete.

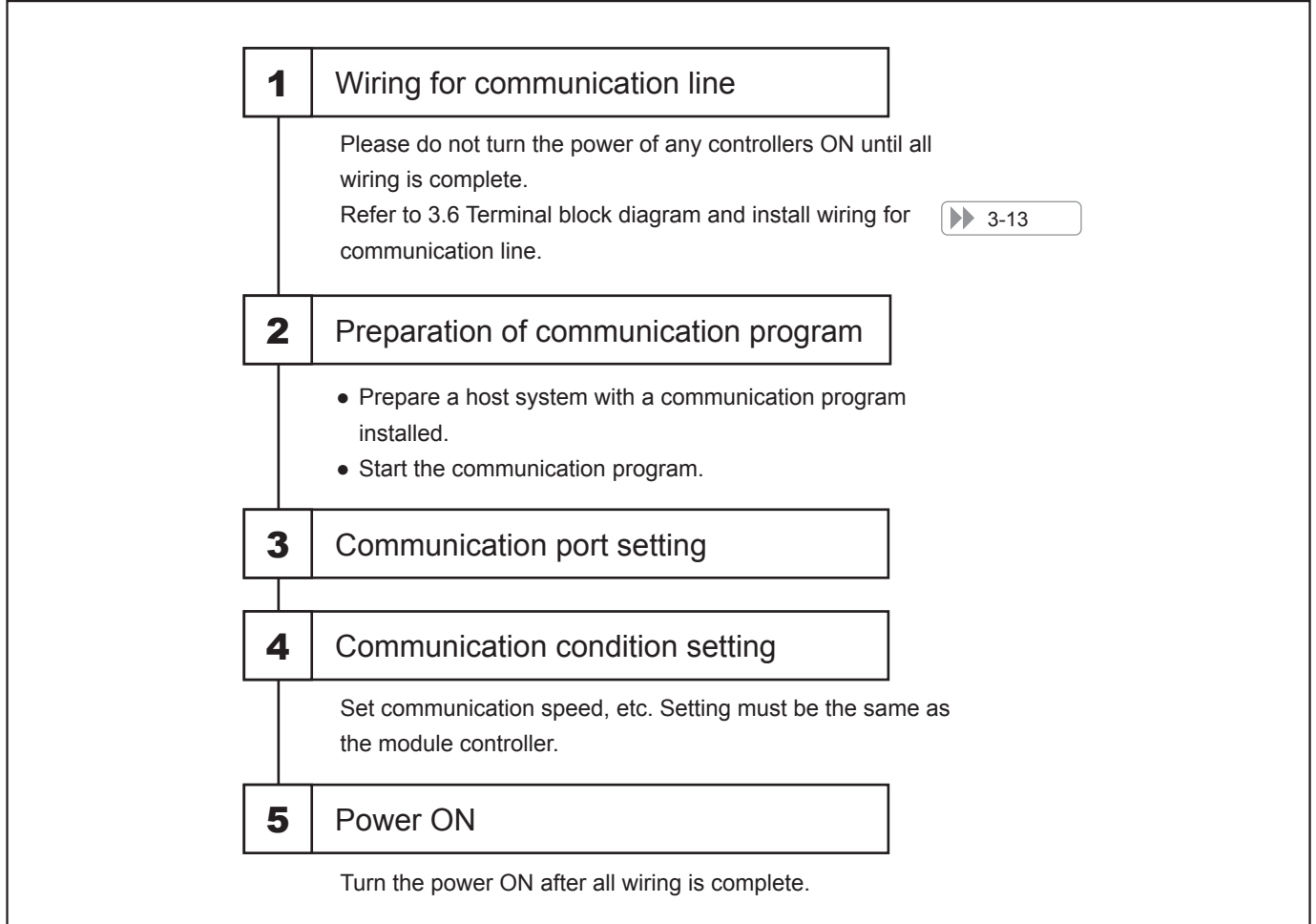

# 3.2 Dimensions

## Dimensions

Refer to the dimensions shown below and provide enough clearance space when installation controllers.

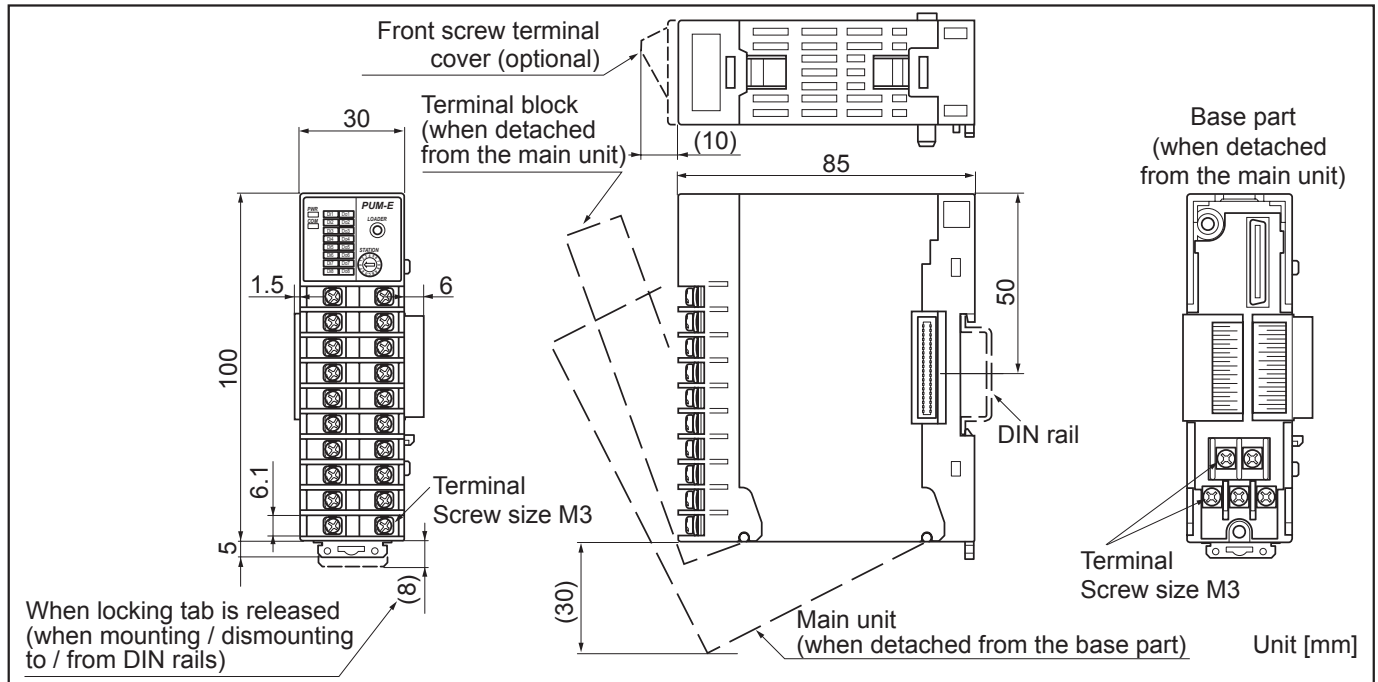

### Cautions when mounting

In order to aid heat dissipation, 30mm of clearance (50mm recommended) above and under the controllers should be provided.

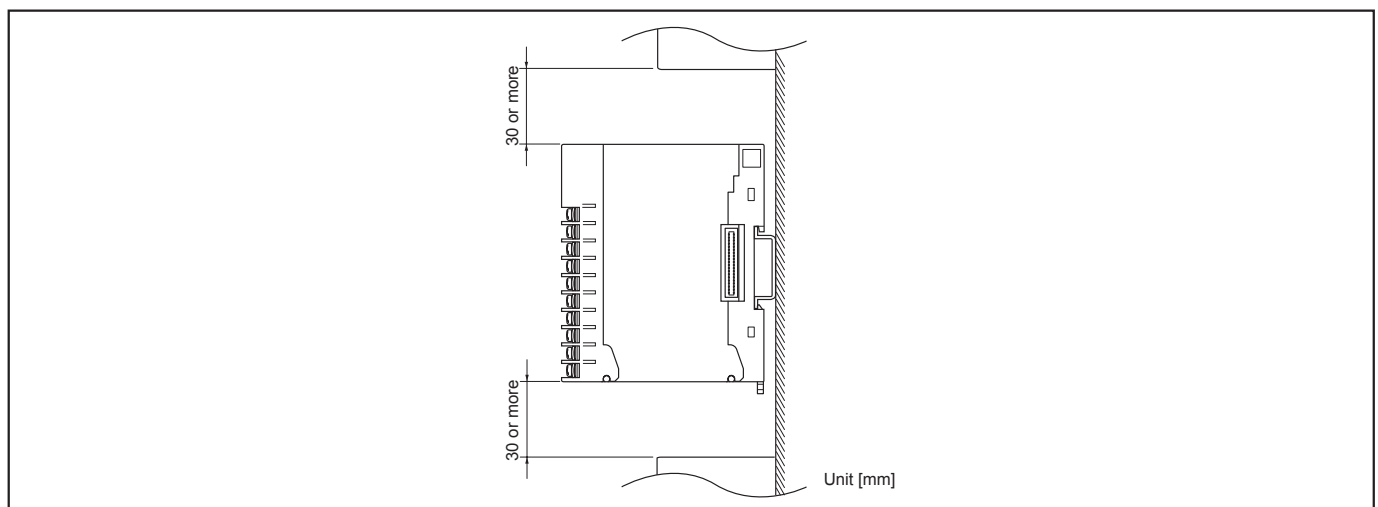

#### Point

When mounting / dismantling controllers to / from DIN rails, 30mm of clearance above and under the controllers should be provided.

# 3.3 Mounting Controllers

## How to Remove Front Terminal Block / Base Part from the Main Unit

Front terminal block and base part of this equipment are removable from the main unit without tools in seconds, which enables easy mounting and maintenance.

### How to remove front terminal block

1. Press the lock lever on the top of the main unit.
2. Pull down the front terminal block.
3. Detach the cutout on the lower end of the front terminal block from the projection on the main unit.

**Point**

- When attaching the front terminal block to the main unit, take the reverse procedure to removing the front terminal block from the main unit.
- Make sure that the lock lever of the main unit is fitted into the front terminal block.

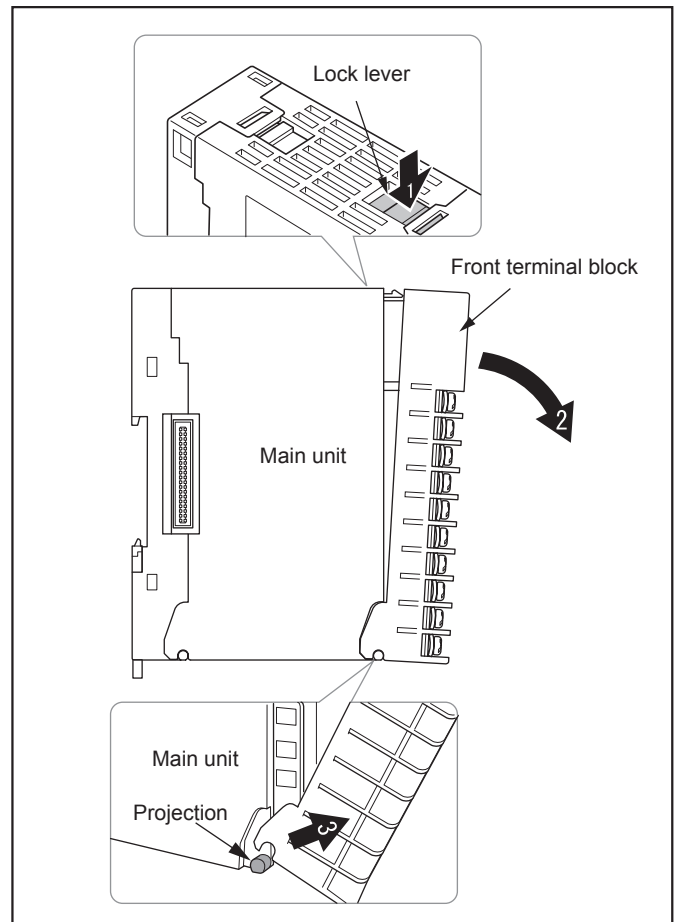

### How to remove base part

1. Press the lock lever on the top of the main unit.
2. Pull down the upper part of main unit.
3. Detach the cutout on the lower end of back of main unit from the projection on the base part.

#### Point

- When attaching the base part to the main unit, take the reverse procedure to removing the base part from the main unit.
- Make sure that the lock lever of the main unit is fitted into the base part.

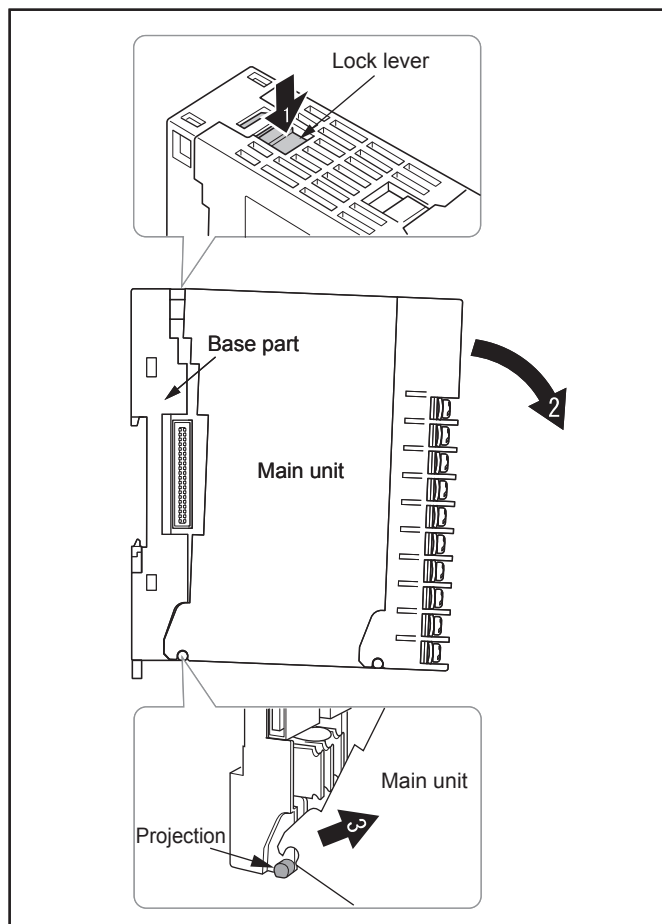



## Mounting to DIN Rails

### Mounting controllers

1. Pull down the locking tab of the base part. Hook the back of the controller onto the upper part of DIN rail.
2. Push the controller in the direction of arrow 2.

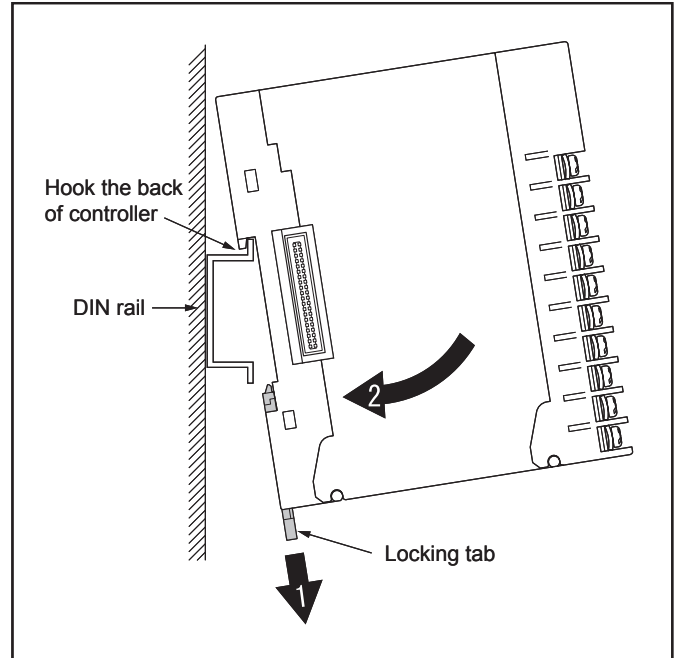

3. Push up the locking tab to fasten the controller onto DIN rail.

#### Point

- When connecting controllers after mounting to DIN rail, push up the locking tab after doing so.

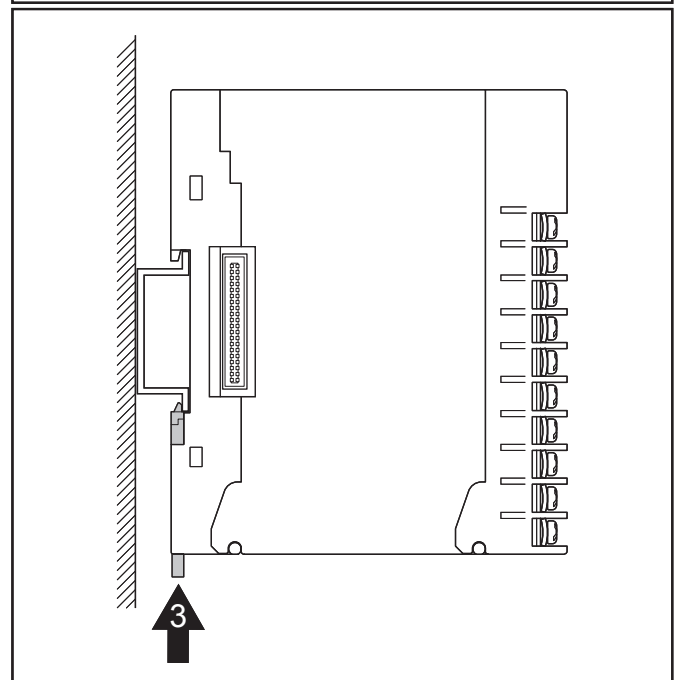

### Connecting controllers

1. Check that locking tabs are pulled down (released).
2. Connect controllers with each other using side connectors.
3. After mounting connected controllers onto DIN rail, make sure to push up all locking tabs. Controllers are fastened to DIN rail and to each other.
4. All connected controllers are connected to power supply and RS-485 via side connectors if one of controllers is directly connected to them.

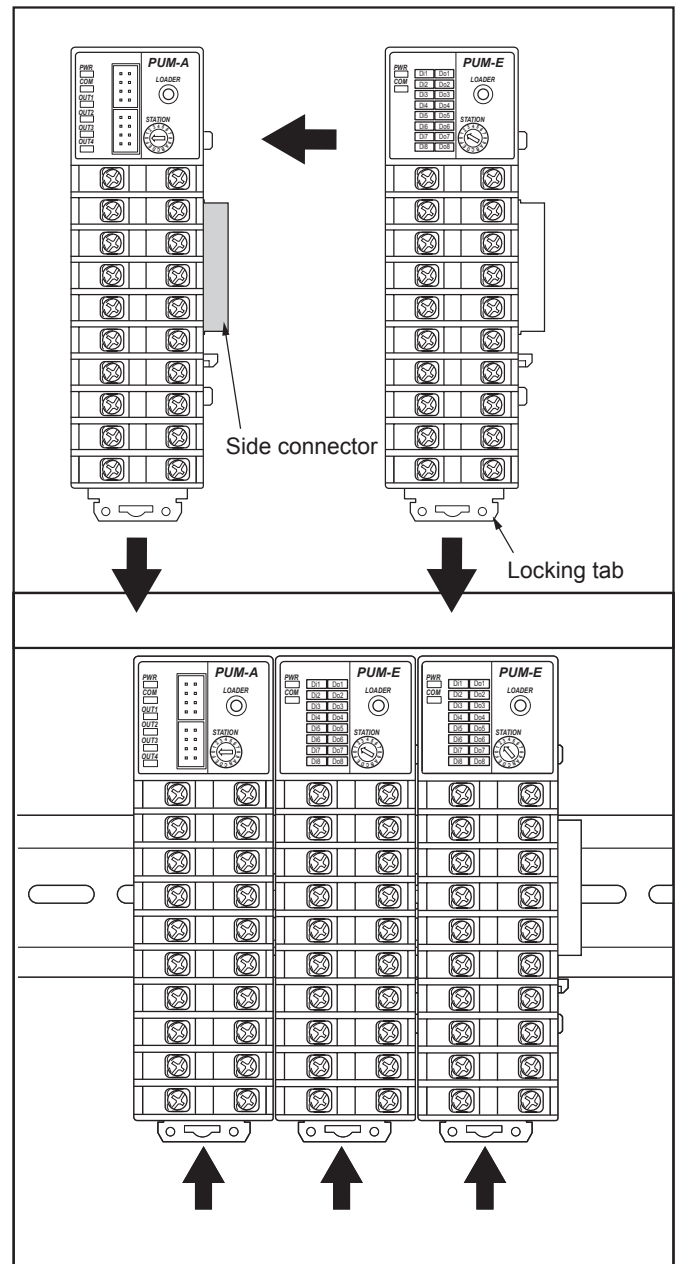

## Order of Controllers

PUM series module type temperature controllers should be connected in the order shown below.

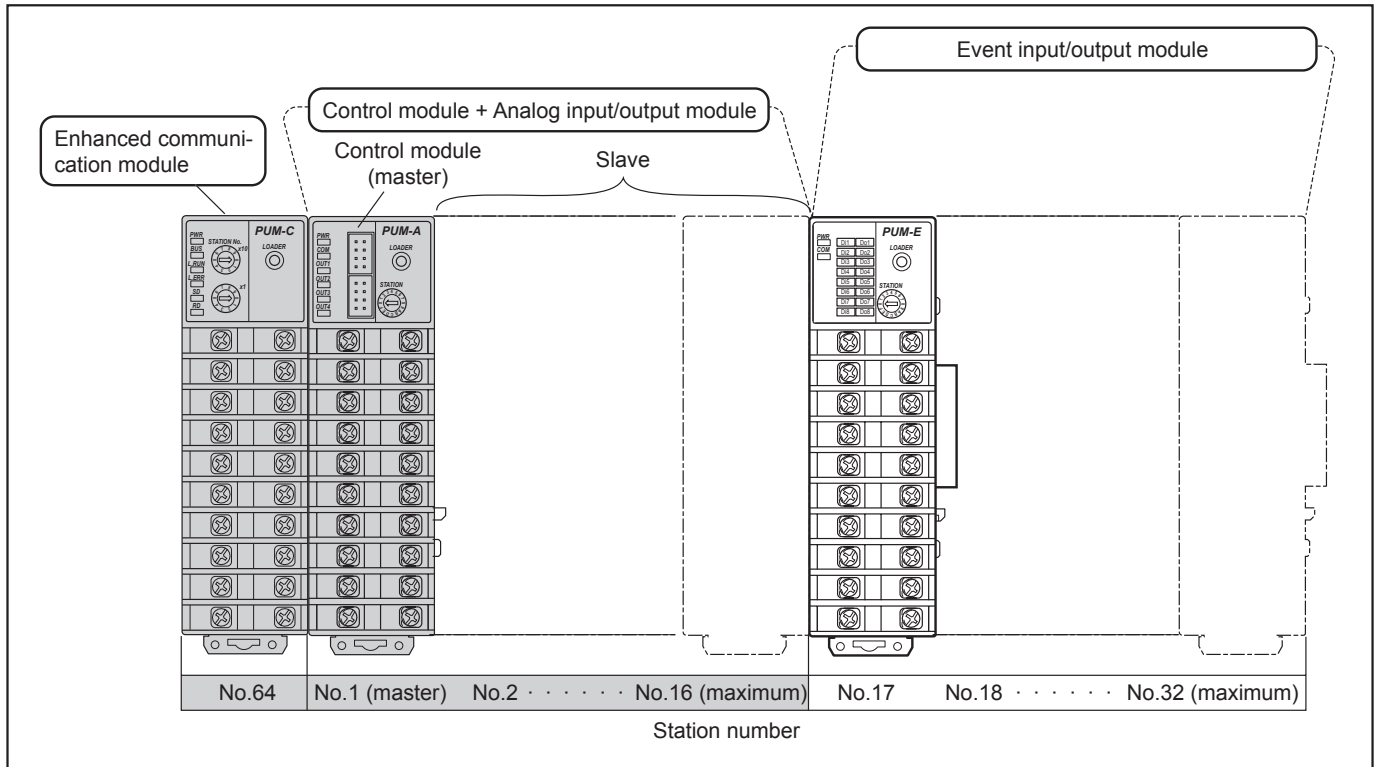

### Point

Basically connect controllers from left to right in the order of station number.

- Assign station numbers 1 to 16 to control module and analog input/output module. Maximum 16 units in total can be connected. Make sure that there is no duplicate station number in the same system.
- When setting slave or master, set the control module controller of station No.1 as the master controller. The master controller should be on the extreme left if an enhanced communication module is not used.
- Assign station numbers 17 to 32 to event input/output module controllers. Maximum 16 units can be connected. Make sure that there is no duplicate station number in the same system.

When using an enhanced communication module, always remember to place it on the extreme left.

- An enhanced communication module should be on the left of the master control module controller, which makes it at the far left end of connected controllers.

# 3.4 Attaching Accessories (Optional)

## Attaching Side Connecting Terminal Covers

Side connectors on the both ends of connected controllers are exposed. To prevent accidents and to protect them, we recommend to attach side connecting terminal covers (PUMZ\*A03) to the ends of the rightmost and leftmost controllers.

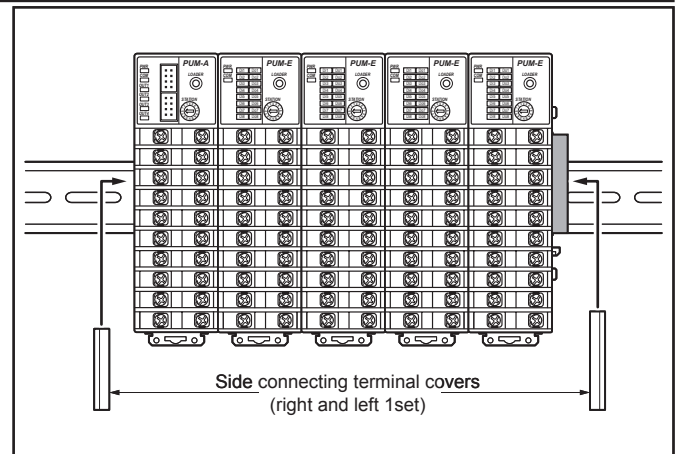

## Attaching End Plates

In order to secure controllers onto DIN rail more tightly, end plates (PUMZ\*A02) can be used.

### Note

- When attaching end plates, make sure to attach side connecting terminal covers first.

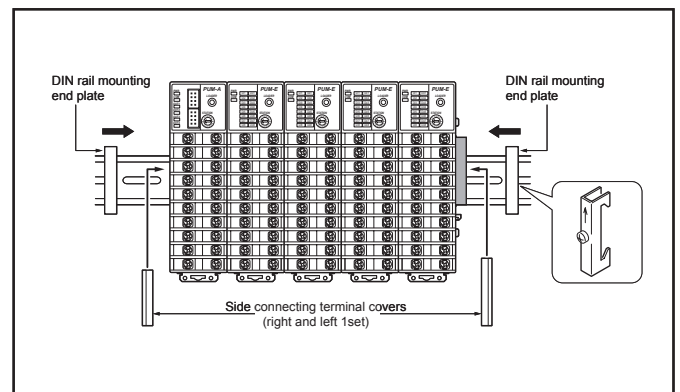

# 3.5 Mounting with Screws

When mounting controllers with screws inside a cabinet, check the screw hole size of the base part and the mounting position beforehand.

**Point**

- Mounting screws are not included in the product. Prepare two M3 screws per unit.

1. Refer to the right figure for the mounting screw hole size and the pitch to decide the mounting position.

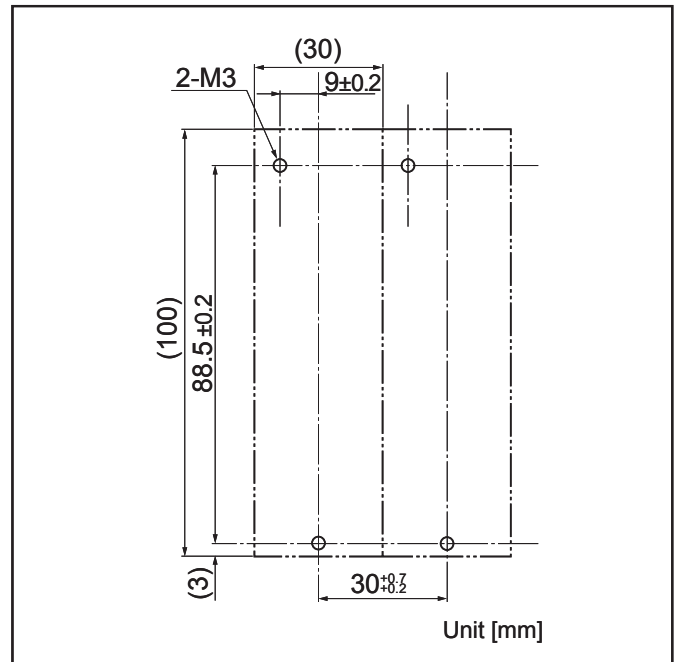

2. Remove the main units from the base parts.  
See [3.3 Mounting controllers] [▶▶ 3-6](#)
3. Connect base parts. Push up to fasten all the locking tabs.
4. Fixate the base parts onto the mounting position inside the cabinet with screws.
5. Attach the main units to the base parts.

# 3.6 Terminal Block Diagram

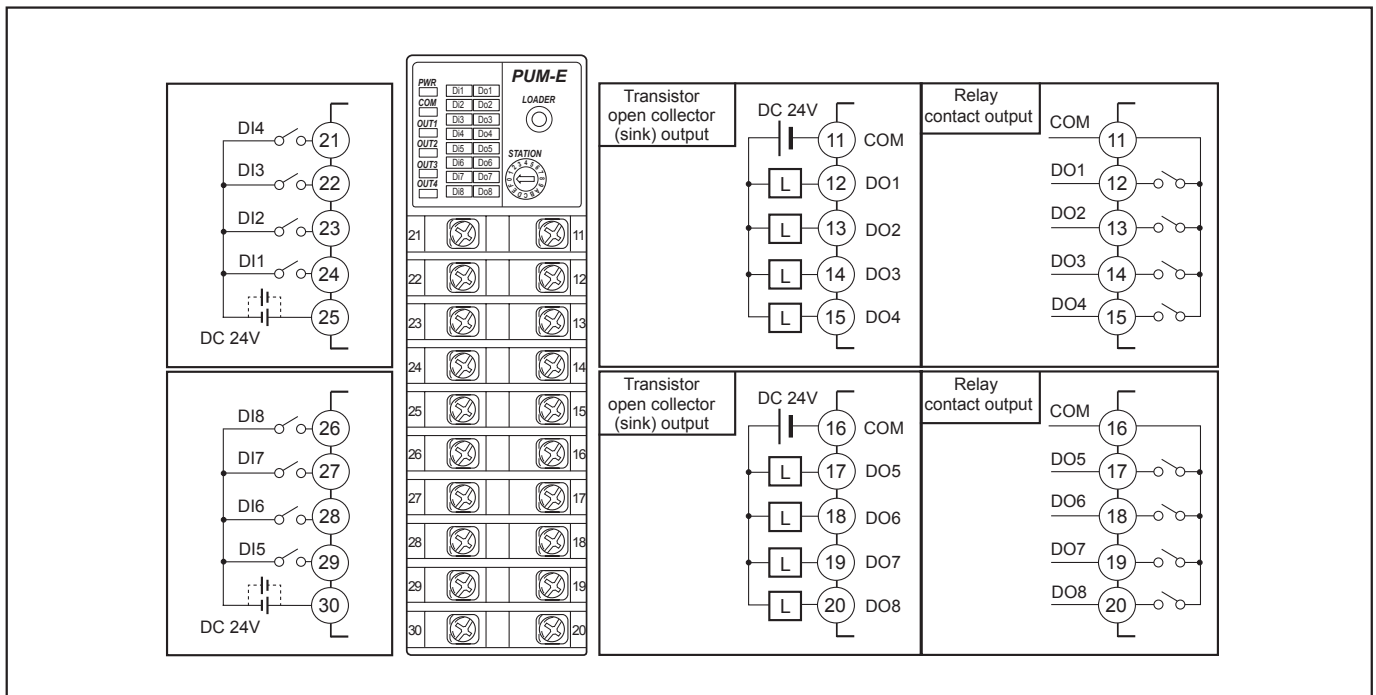

## Wiring



### Point

- For digital input (voltage contact input), external power supply 24V DC is required. The input is common for sink and source and used for both directions.
- For digital output (relay output), external power supply for drive load is required. The contact capacity of relay output relay is 220V AC/30V DC, 1A.
- For digital output (transistor open collector output), external power supply for drive load is required. The rating capacity of the output transistor is 24V DC, 100mA. (Residual voltage when power is ON: 1.5V DC or less)
- Note that the insulation class for this equipment is as follows. Before installing, please confirm that the insulation class for this equipment meets usage requirements.

Power	Di1 to 4
Loader communication port	Di5 to 8
RS-485 communication port	Do1 to 4
	Do5 to 8

 Functional insulation (1000V AC)  
 Functional insulation (500V AC)

## Wiring for Power Supply / RS-485

### Terminal layout

Power terminal and RS-485 terminal are on the base part of each controller.

The terminal layout of all controllers is the same.

Power supply and RS-485 are connected to connected controllers via side connectors if one of controllers is directly connected to them.

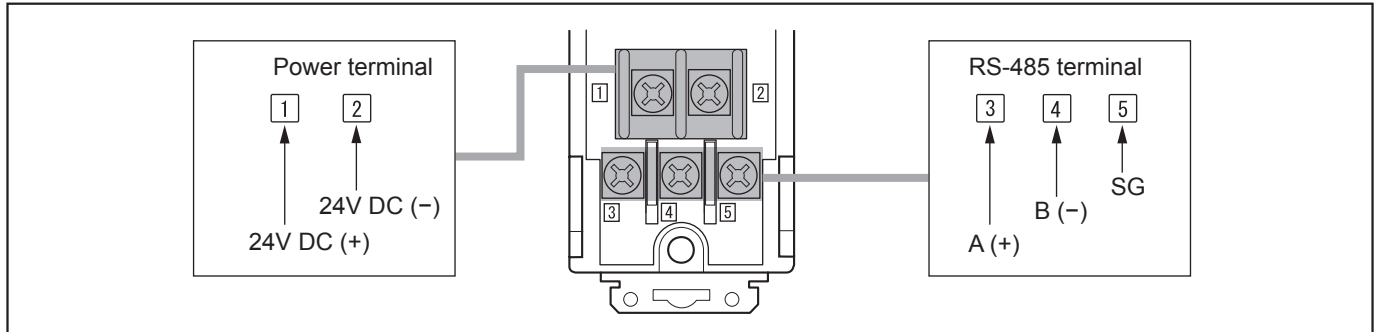

#### Note

- For wiring to the terminal block, apply crimp type terminals size M3.  
Make sure to use screws included in this product only.  
Screw size : M3×7 (with square washer)  
Screw tightening torque : 0.78N·m (8kgf·cm)
- Apply power cable with allowable current capacity larger than total consumption current of all connected controllers.
- For wiring to RS-485, a cable equivalent to KPEV-SB 0.5sq should be used.
- For wiring to power terminal, do not apply more than two cables to be terminal. (Power cable should be connected to power terminal directly from the power unit.)
- Please prepare power cables and crimp terminals of the size indicated below.

#### Power cable

Cable type	Size
Thermocouple (Compensation lead wire)	1.25mm <sup>2</sup> or less
Power supply	1.25mm <sup>2</sup> or less

#### Crimp terminal

Cable size	Screw tightening torque
0.25 to 1.25mm <sup>2</sup>	0.8N·m

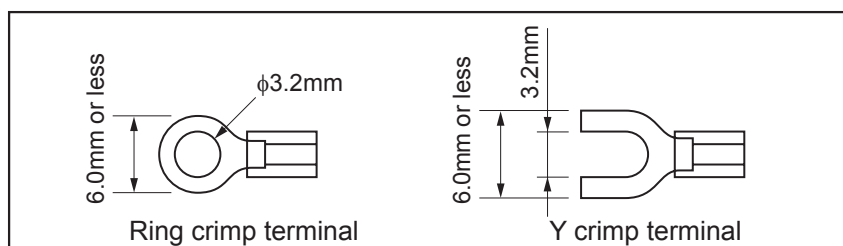

### Connection of RS-485 terminating resistance

RS-485 terminating resistance should be connected to the controller at the opposite end from the controller to which RS-485 communication line is connected.

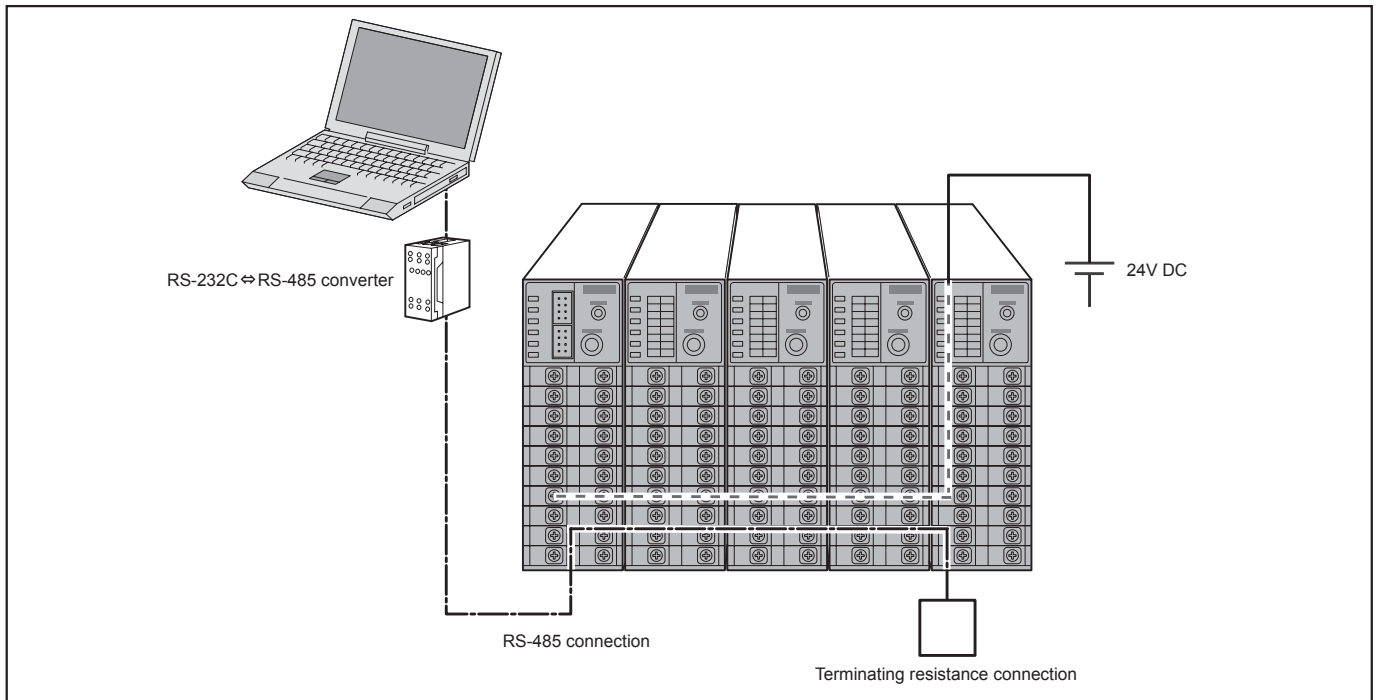



# 4

## System Setting

4.1	Operating Method.....	4-3
4.2	Input Setting .....	4-7
4.3	Output Setting .....	4-15
4.4	Communication Setting .....	4-35
4.5	Monitor .....	4-39



---

# 4.1 Operating Method

---

## Operating Method

---

The following operations can be performed while running this equipment:

### Control Value Operation

- DO Latch Release  4-4
- DI Latch Release  4-5
- Run/Standby Switch  4-5

## DO Latch Release

It is for releasing DO (Digital Output) latch.

It has the parameter shown below:

Parameter	Range	Unit	Factory Default	Attribute	MODBUS Register Number (Relative Address)
Digital output latch releases command	0: OFF 1: Latch Release	None	0	R / W	40023 (0016h)

When the DO latch specification bit is ON (valid) in Output Option Settings from DO1 to DO8 [▶▶ 4-20](#), the DO signal is latched. To release the latch, set “1” to the DO latch releases command. The DO latch release command will automatically be “0” after the latch is released.

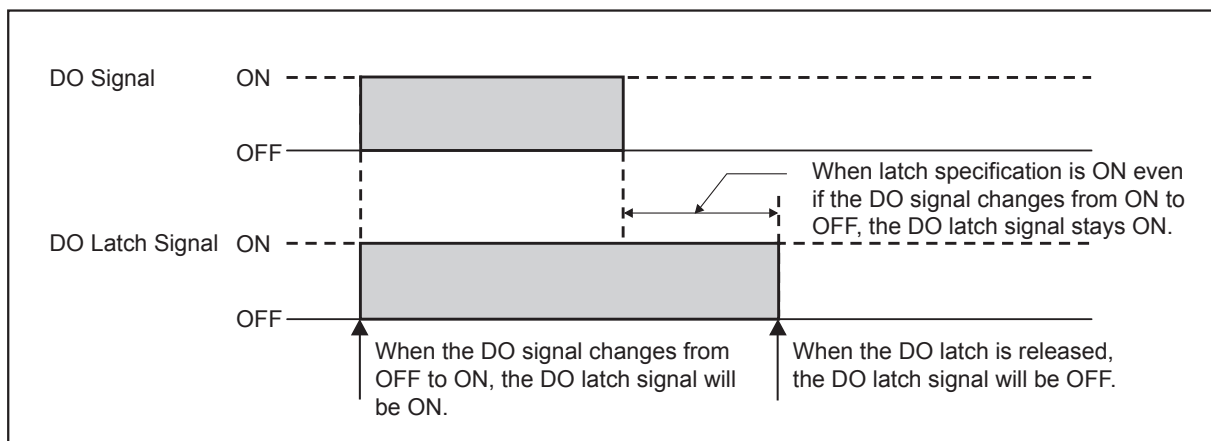

If “1” is set to “DO Latch Release Command,” latch of all from DO1 to DO8 can be released.

### Note

The DO latch function will be valid when the “Output Type Setting” [▶▶ 4-17](#) is “0” (event output).

## DI Latch Release

It is for releasing DI (Digital Input) latch.

It has the parameter shown below:

Parameter	Range	Unit	Factory Default	Attribute	MODBUS Register Number (Relative Address)
Digital input latch releases command	0: OFF 1: Latch Release	None	0	R / W	40022 (0015h)

When the latch specification bit of DI transferred to the control module is ON (valid) in Input Option Settings from DI1 to DI8 [▶▶ 4-8](#), the DI signal is latched. To release the latch, set "1" to the DI latch releases command. The DI latch release command will automatically be "0" after the latch is released.

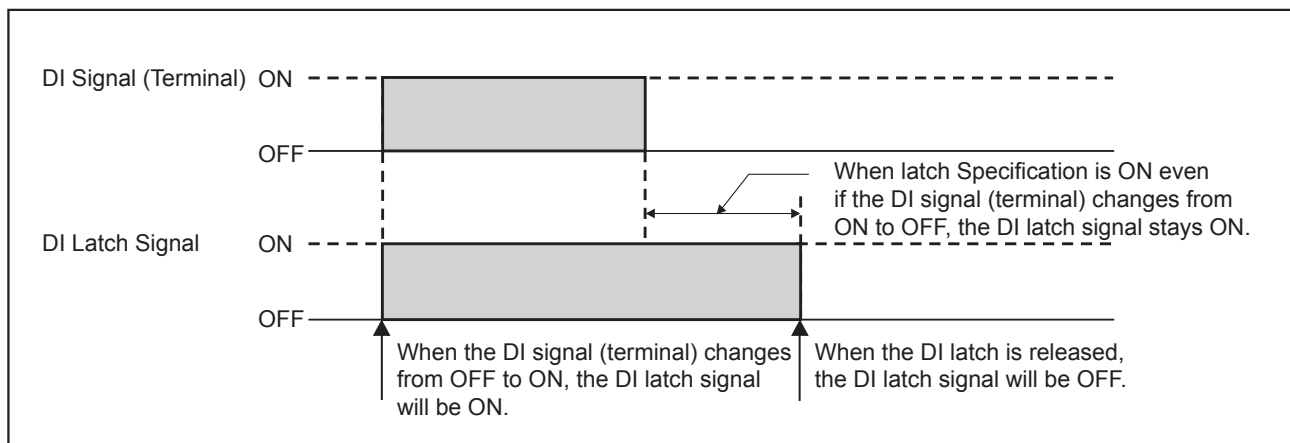

If "1" is set to "DI Latch Releases Command," the latch of all from DO1 to DO8 can be released.

## RUN/Standby Switch

It is for setting either operation mode or standby mode for this equipment.

It has the parameter shown below:

Parameter	Range	Unit	Factory Default	Attribute	MODBUS Register Number (Relative Address)
Run/Standby switch	0: RUN 1: Standby	None	0	R / W	40021 (0014h)

The DI transfer value and DO output value in the standby mode should be set according to "Standby Mode Setting" [▶▶ 4-32](#), and "Standby Output Setting" [▶▶ 4-32](#).



# 4.2 Input Setting

## Input Setting

It is for setting the digital input (DI).

- DI Input Option ▶▶ 4-8
- Input NOT Setting ▶▶ 4-10
- Input AND Setting ▶▶ 4-11
- Input OR Setting ▶▶ 4-13

### Digital Input Setting

This equipment has 8 digital input terminals (DI1 to DI8), and 8 input registers (DI1 to DI8).

Calculation is done based on the value that has been input from outside hardware to the terminal and the set value of each parameter. The calculation result will be stored in the internal register.

The value stored in the internal register will be transferred to the control module or PLC operation module through inter-module communication.

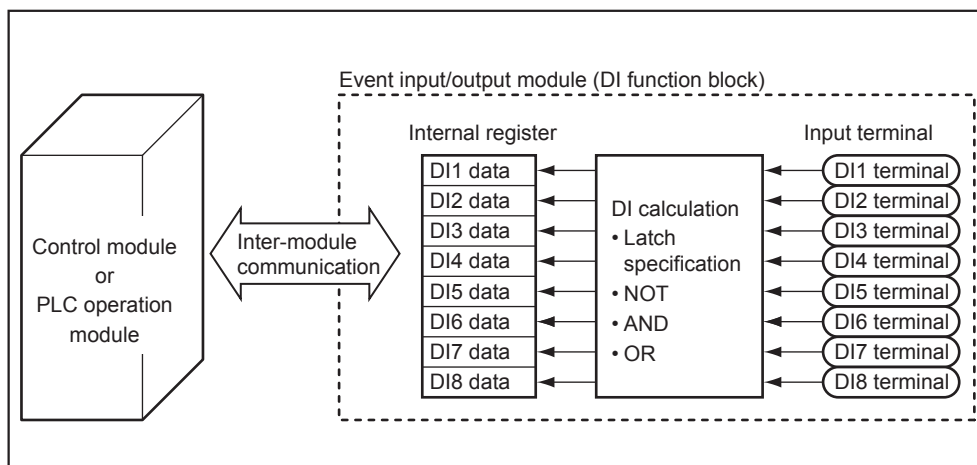

## DI Input Option Setting

It is for setting valid/invalid of the option function for each DI input.

Each DI input has parameter shown below:

Parameter	Range	Unit	Factory Default	Attribute	MODBUS Register Number (Relative Address)
DI1 input option to DI8 input option	0 to 15	None	0	R / W	DI1:40701 (02BCh)
					DI2:40705 (02C0h)
					DI3:40709 (02C4h)
					DI4:40713 (02C8h)
					DI5:40717 (02CCh)
					DI6:40721 (02D0h)
					DI7:40725 (02D4h)
					DI8:40729 (02D8h)

### Set value of DI Input Option

Set "1" to all option bits to be used. For the actual set value, input a value by converting a binary digit to a decimal number.

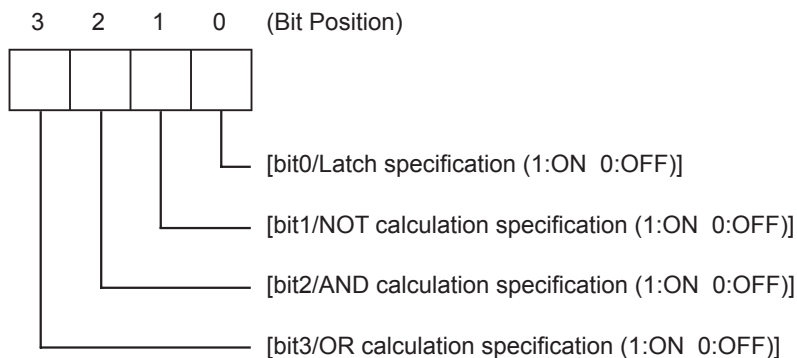

- Latch Specification**

It is for setting whether to hold (latch) ON when the target DI is ON. To release the latch, "DI Latch Release" [▶▶ 4-5](#) must be performed.

- NOT Calculation Specification**

The input of specified DI will be inverted.

- AND Calculation Specification**

When the DI inputs specified in the "Input AND Setting" [▶▶ 4-11](#) are all "ON", the value of the target DI will be "ON."

- OR Calculation Specification**

When any one of the DI inputs specified in the "Input OR Setting" [▶▶ 4-13](#) is "ON," the value of the target DI will be "ON."



### DI Input Calculation Flow

DI inputs are calculated in the following sequence:

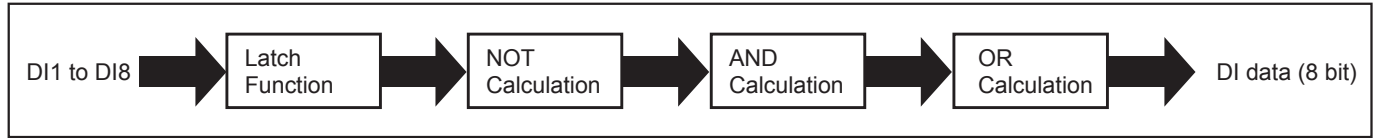

Each DI has all DI statuses for calculation. Using this DI status, calculation of the target DI is performed.

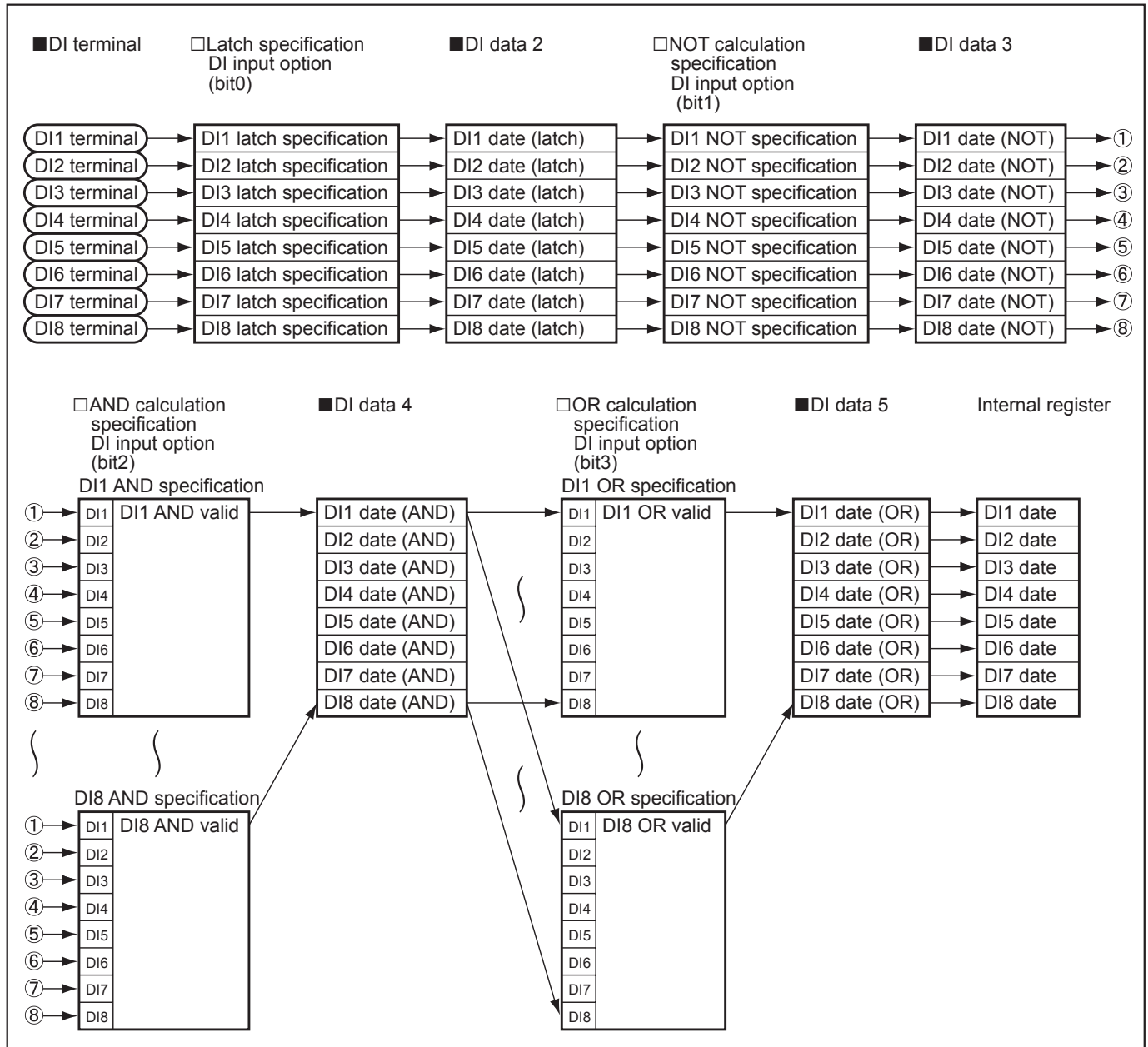

### **Input NOT Setting**

---

It is for setting whether to perform NOT calculation for each DI input.

The DI input of which bit 1 is "1" (ON) in the "DI Input Option" [▶▶ 4-8](#) will be inverted for inputting.

The "Input AND Setting" [▶▶ 4-11](#) and "Input OR Setting" [▶▶ 4-13](#) use the DI input in which the result of the "Input NOT Setting" is reflected.

#### **Note**

---

If DI is latched, the latch is performed with the input inverted.

---

## Input AND Setting

It is for setting the DI input for AND calculation.

Each DI input has the parameter shown below:

Parameter	Range	Unit	Factory Default	Attribute	MODBUS Register Number (Relative Address)
DI1 input logic operation AND to DI8 input logic operation AND	0000h to 00FFh	None	0000h	R / W	DI1:40703 (02BEh)
					DI2:40707 (02C2h)
					DI3:40711 (02C6h)
					DI4:40715 (02CAh)
					DI5:40719 (02CEh)
					DI6:40723 (02D2h)
					DI7:40727 (02D6h)
					DI8:40731 (02DAh)

### Set Value of Input AND Setting

The DI input for AND calculation will be specified by a bit. When the specified DI inputs are all ON, the target DI value will be "1."

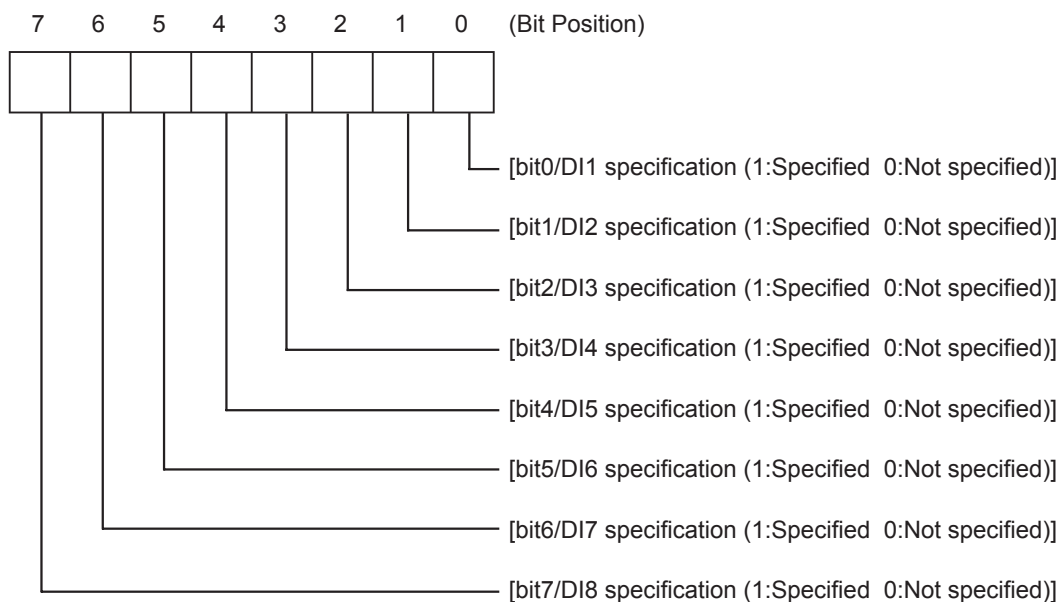

## 4.2 Input Setting

---

- **An example of use**

When the inputs of DI1, DI3, and DI5 are all ON, if you want to set “1” to DI1 to be transferred to control module:

The DI1 input AND setting will be as follows:

**“DI1 Input logic operation AND” : 0001 0101b**  
**: 0015h**

After the above setting is performed, DI1 value to be transferred will be “1” only when DI1, DI3 and DI5 are all ON, and will be “0” when not all of them are ON.

DI1	DI3	DI5	DI1 value to be transferred
ON	ON	ON	1
ON	ON	OFF	0
ON	OFF	ON	0
ON	OFF	OFF	0
OFF	ON	ON	0
OFF	ON	OFF	0
OFF	OFF	ON	0
OFF	OFF	OFF	0

## Input OR Setting

It is for setting the DI input for OR calculation.

Each DI input has the parameter shown below:

Parameter	Range	Unit	Factory Default	Attribute	MODBUS Register Number (Relative Address)
DI1 input logic operation OR to DI8 input logic operation OR	0000h to 00FFh	None	0000h	R / W	DI1:40704 (02BFh)
					DI2:40708 (02C3h)
					DI3:40712 (02C7h)
					DI4:40716 (02CBh)
					DI5:40720 (02CFh)
					DI6:40724 (02D3h)
					DI7:40728 (02D7h)
					DI8:40732 (02DBh)

### Set Value of Input OR Setting

The DI input for OR calculation will be specified by a bit. If any one of specified DI inputs is ON, the target DI will be "1."

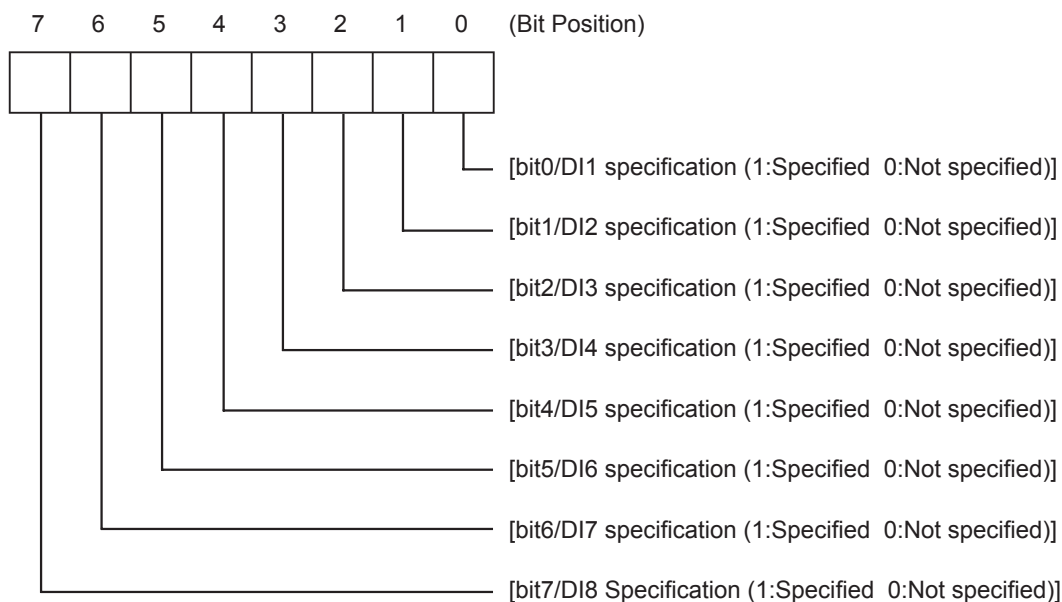

## 4.2 Input Setting

---

- **An example of use**

When any one of the inputs of DI1, DI3 and DI5 is ON, if you want set "1" to the transfer output of DI1:

DI1 input OR should be set as follows:

**"DI1 input logic operation OR" : 0001 0101b**  
**: 0015h**

After the above setting is performed, the value of DI1 to be transferred will be "1" when any one of the inputs of DI1, DI3 and DI5 is ON, and the value will be "0" when all of them are OFF.

DI1	DI3	DI5	DI1 value to be transferred
ON	ON	ON	1
ON	ON	OFF	1
ON	OFF	ON	1
ON	OFF	OFF	1
OFF	ON	ON	1
OFF	ON	OFF	1
OFF	OFF	ON	1
OFF	OFF	OFF	0

# 4.3 Output Setting



## Output Setting

On this equipment, digital output (DO) types can be used by changing them to the event output or the control output.

### Output Type Setting

- Output Types [▶▶ 4-17](#)

For explanations of the following settings, icons are also shown according to the output type that needs to be set.

- Event Output ..... 
- Control Output ..... 

Setting must be performed according to the selected output type.

### Output Settings for Event Output

- Output Source [▶▶ 4-18](#)
- BIT Position Specification [▶▶ 4-19](#)
- DO Output Option [▶▶ 4-20](#)
- Output NOT Setting [▶▶ 4-22](#)
- Output AND Setting [▶▶ 4-23](#)
- Output OR Setting [▶▶ 4-25](#)
- Internal DO Area [▶▶ 4-31](#)

### Output Settings for Control Output

- Output Source [▶▶ 4-18](#)
- Output Scaling Base and Span Setting [▶▶ 4-27](#)
- DO Proportional Cycle [▶▶ 4-28](#)
- Output Limit [▶▶ 4-29](#)
- Internal DO Area [▶▶ 4-31](#)

### Other settings

- Standby Output Set Value [▶▶ 4-32](#)
- FAULT Output 1 Set Value [▶▶ 4-33](#)

### Digital Output

This equipment has 8 digital output terminals (DO1 to DO8), and 8 output registers (DO1 to DO8).

The digital output data that have been transferred from the control module and PLC operation module through internal communication will be put in the internal register for each DO. Then, logic calculation will be performed and the calculated result will be output from the digital output terminal.

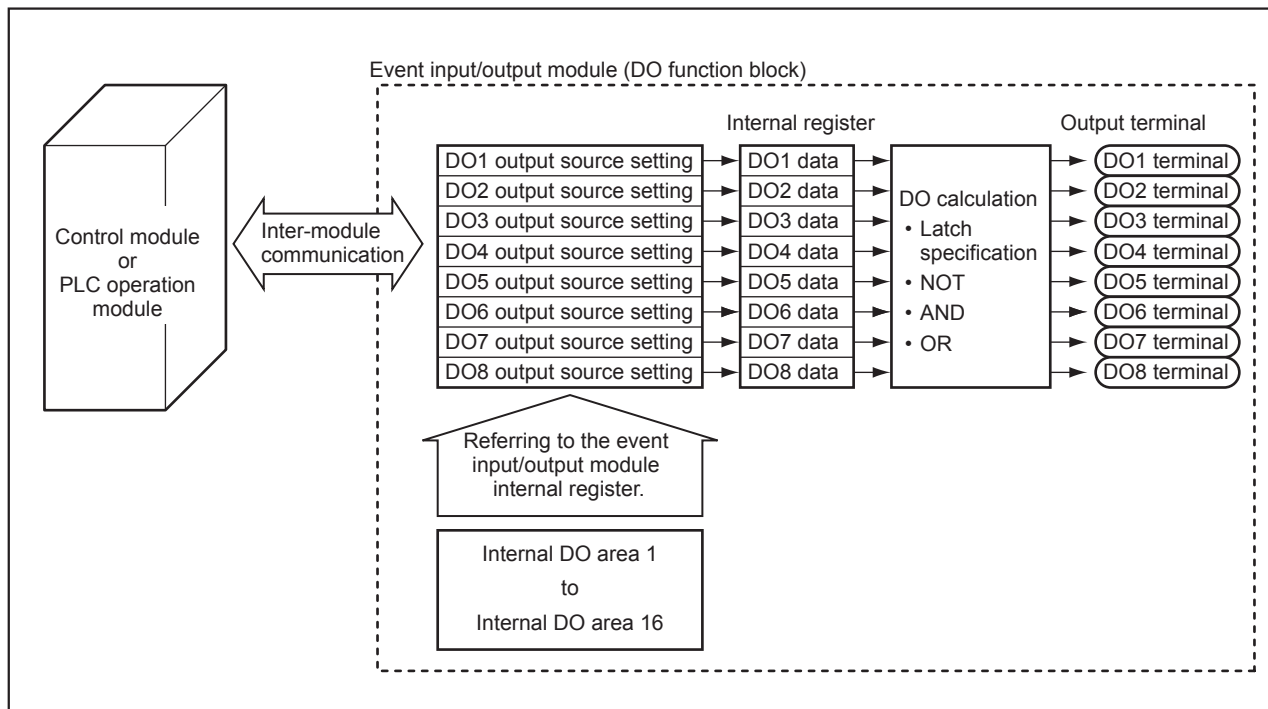



## Output Types

It is for setting an output type for each DO output terminal.

Each DO output terminal has the parameter shown below:

Parameter	Range	Unit	Factory Default	Attribute	MODBUS Register Number (Relative Address)
DO1 output type to DO8 output type	0: Event Output 1: Control Output	None	0	R / W	DO1:40401 (0190h)
					DO2:40415 (019Eh)
					DO3:40429 (01ACh)
					DO4:40443 (01BAh)
					DO5:40457 (01C8h)
					DO6:40471 (01D6h)
					DO7:40485 (01E4h)
					DO8:40499 (01F2h)

### Output Value from DO Output Terminal

- **When the output type is “0” (event output):**

The event of the output source  will be output from DO output terminal.

- **When the output type is “1” (control output):**

The output value from the output source  will be output from the DO output terminal.

## Output Source

Event

Control

It is for setting the master station number and channel number of the reference and output source module for each DO output terminal.

Each DO output terminal has the parameter shown below:

Parameter	Range	Unit	Factory Default	Attribute	MODBUS Register Number (Relative Address)
DO1 Master module St. No. to DO8 Master module St. No.	0 to 16	None	0	R / W	DO1:40402 (0191h)
					DO2:40416 (019Fh)
					DO3:40430 (01ADh)
					DO4:40444 (01BBh)
					DO5:40458 (01C9h)
					DO6:40472 (01D7h)
					DO7:40486 (01E5h)
					DO8:40500 (01F3h)
DO1 Master module Ch. No. to DO8 Master module Ch. No.	1 to 4	None	1	R / W	DO1:40403 (0192h)
					DO2:40417 (01A0h)
					DO3:40431 (01AEh)
					DO4:40445 (01BCh)
					DO5:40459 (01CAh)
					DO6:40473 (01D8h)
					DO7:40487 (01E6h)
					DO8:40501 (01F4h)

### Master module St. Setting and Master module Ch. Setting

- Set "the reference/output source module number (the rotary switch position + 1)" to the master module St. No. Set "the reference/output source channel number" to the master module Ch. No.
- If "0" is set to the master module St. No., the corresponding internal DO area  4-31 will be referred as the output source.

## Bit Position Specification

Event

It is for specifying the reference data by the bit position for each DO output terminal.

Parameter	Range	Unit	Factory Default	Attribute	MODBUS Register Number (Relative Address)
DO1 BIT position to DO8 BIT position	0000h to 00FFh	None	0000h	R / W	DO1:40404 (0193h)
					DO2:40418 (01A1h)
					DO3:40432 (01AFh)
					DO4:40446 (01BDh)
					DO5:40460 (01CBh)
					DO6:40474 (01D9h)
					DO7:40488 (01E7h)
					DO8:40502 (01F5h)

### Bit Position Specification Setting

The operation status (bit 10, 12 to 15) and the state of event outputs from 1 to 5 (bit 0 to 4) of each Ch. of reference module can be referred as 16-bit data.

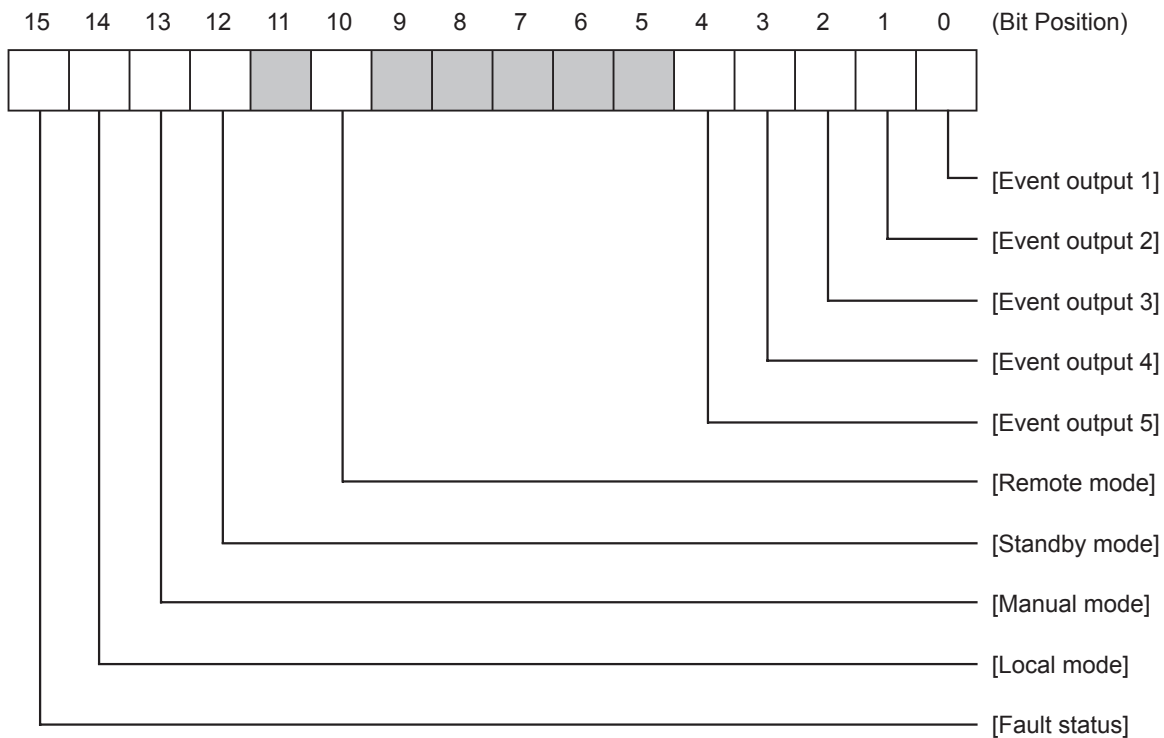

The values obtained by OR calculation of specified bits will be the reference data for DO output.

For event output settings from 1 to 5, refer to the Users Manual for the control modules.

# DO Output Option

Event

It is for setting valid/invalid of the option function for each DO output.

Each DO output has the parameter shown below:

Parameter	Range	Unit	Factory Default	Attribute	MODBUS Register Number (Relative Address)
DO1 output option to DO8 output option	0000h to 000Fh	None	0000h	R / W	DO1:40405 (0194h)
					DO2:40419 (01A2h)
					DO3:40433 (01B0h)
					DO4:40447 (01BEh)
					DO5:40461 (01CCh)
					DO6:40475 (01DAh)
					DO7:40489 (01E8h)
					DO8:40503 (01F6h)

## Set value of DO Output Option

DO output option settings will be specified by a bit. The option function of which bit is "ON" will be performed.

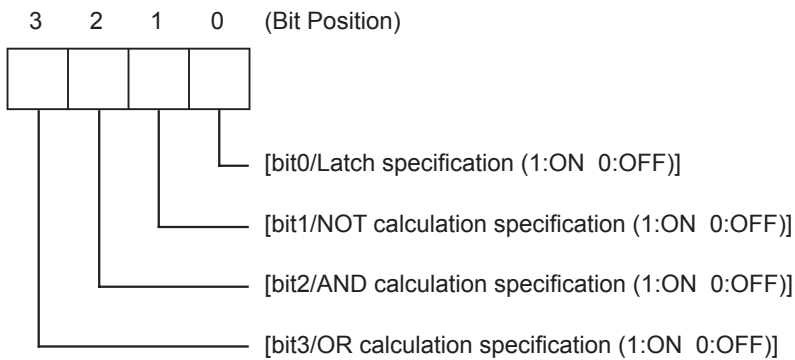

- Latch Specification**

It is for setting whether to hold ON when the target DO is ON. To release the latch, "DO Latch Release" ▶▶ 4-4 must be performed.

- NOT Calculation Specification**

The DO output will be inverted.

- AND Calculation Specification**

When the DO outputs of the bit position specified in the "Input AND Setting," ▶▶ 4-11 are all "ON," the value of the target DO should be "ON."

- OR Calculation Specification**

When any one of the bits among DO outputs of bit position specified in the "Input OR Setting" ▶▶ 4-13 is "ON," the value of the target DO should be "ON."

### DO Output Calculation Flow

DO output is calculated in the following sequence:

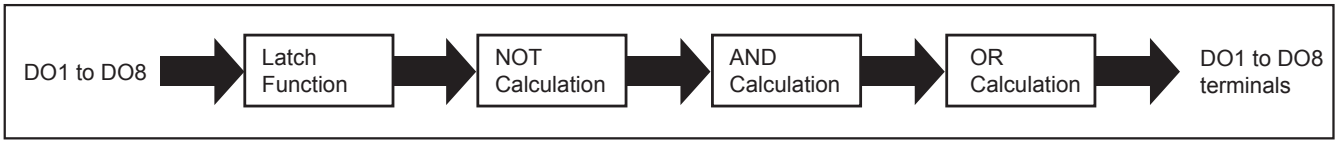

Each DO has all DO status for calculation. Using this DO for calculation, the target DO will be calculated.

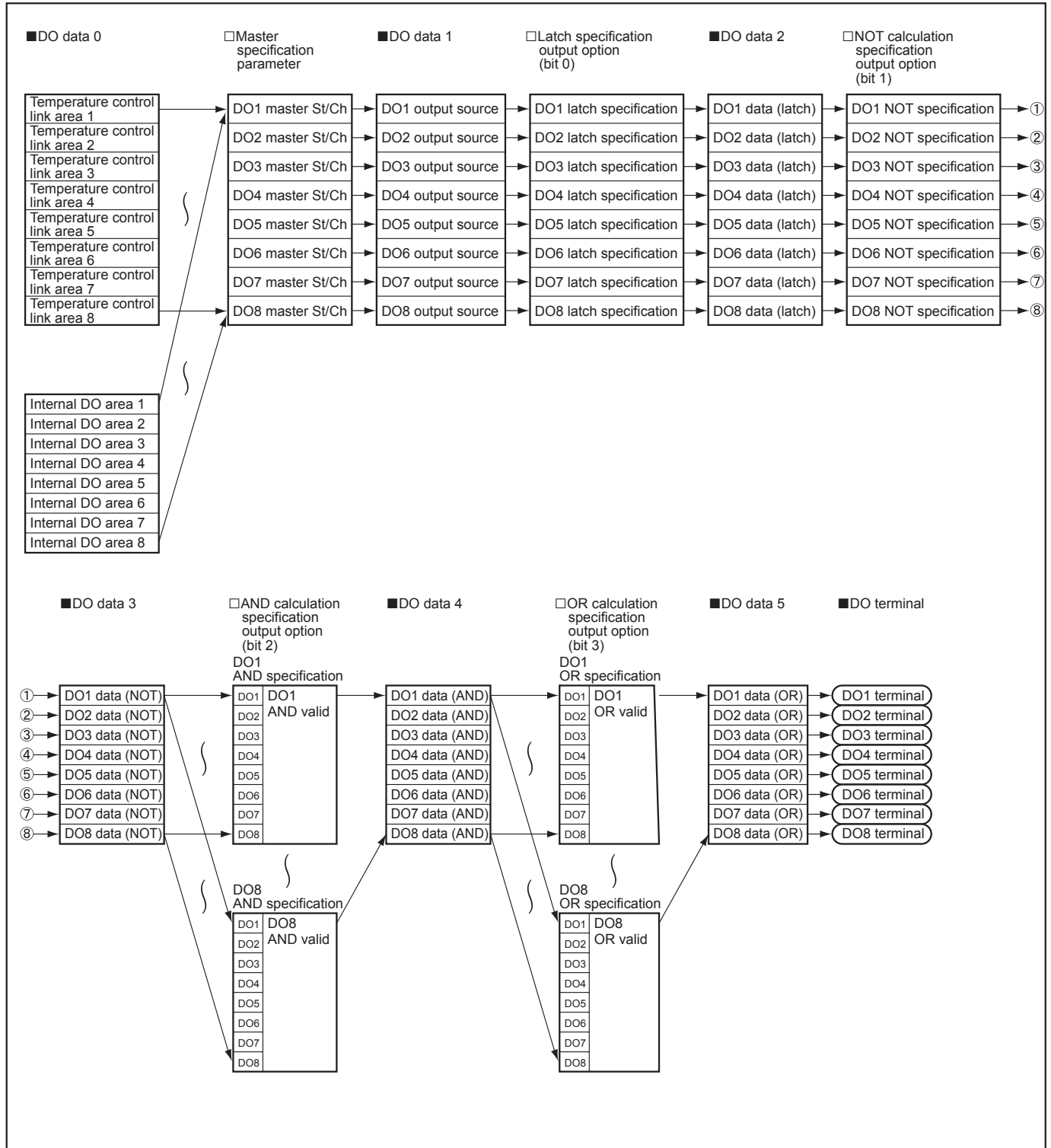

### Output NOT Setting

Event

It is for setting whether to perform NOT calculation for each DO output.

The DO output of which bit 1 in the “DO Output Option” [▶▶ 4-20](#) is “1” (ON) will be inverted and will be output.

The “Output AND Setting” [▶▶ 4-23](#) and “Output OR Setting” [▶▶ 4-25](#) use the DO output in which the result of the “output NOT setting” is reflected.

#### Note

---

If DO is latched, the latch is performed with the output inverted.

---

## Output AND Setting

Event

It is for setting the DO output for AND calculation.

Each DO output has the parameter shown below:

Parameter	Range	Unit	Factory Default	Attribute	MODBUS Register Number (Relative Address)
DO1 output logic operation AND to DO8 output logic operation AND	0000h to 00FFh	None	0000h	R / W	DO1:40407 (0196h)
					DO2:40421 (01A4h)
					DO3:40435 (01B2h)
					DO4:40449 (01C0h)
					DO5:40463 (01CEh)
					DO6:40477 (01DCh)
					DO7:40491 (01EAh)
					DO8:40505 (01F8h)

### Set Value of Output AND Setting

The DO output for AND calculation will be specified by a bit. When the specified DO data are all ON, the target DO value should be "1."

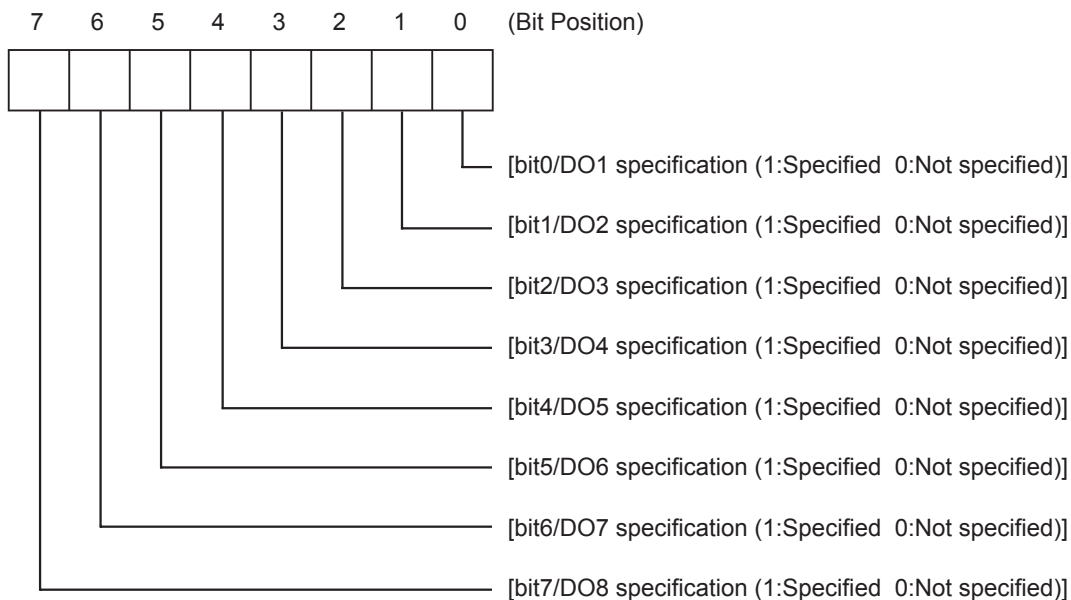

## 4.3 Output Setting

---

- **An example of use**

If you want to set “1” to the output of DO1 terminal when the outputs of DO1, DO3, and DO5 are all ON;

The DO1 output AND setting will be as follows:

**“DO1 Output logic operation AND” : 0001 0101b**  
**: 0015h**

After the above setting is performed, the output value of DO1 terminal will be “1” only when DO1, DO3 and DO5 are all ON, and will be “0” when not all of them are ON.

DO1	DO3	DO5	DO1 terminal output value
ON	ON	ON	1
ON	ON	OFF	0
ON	OFF	ON	0
ON	OFF	OFF	0
OFF	ON	ON	0
OFF	ON	OFF	0
OFF	OFF	ON	0
OFF	OFF	OFF	0



## Output OR Setting

Event

It is for setting the DO output for OR calculation.

Each DO output has the parameter shown below:

Parameter	Range	Unit	Factory Default	Attribute	MODBUS Register Number (Relative Address)
DO1 output logic operation OR  to  DO8 output logic operation OR	0000h to 00FFh	None	0000h	R / W	DO1:40408 (0197h)
					DO2:40422 (01A5h)
					DO3:40436 (01B3h)
					DO4:40450 (01C1h)
					DO5:40464 (01CFh)
					DO6:40478 (01DDh)
					DO7:40492 (01EBh)
					DO8:40506 (01F9h)

### Set value of Output OR setting

The DO output for OR calculation will be specified by a bit. If any one of specified DO data is ON, the target DO should be "1."

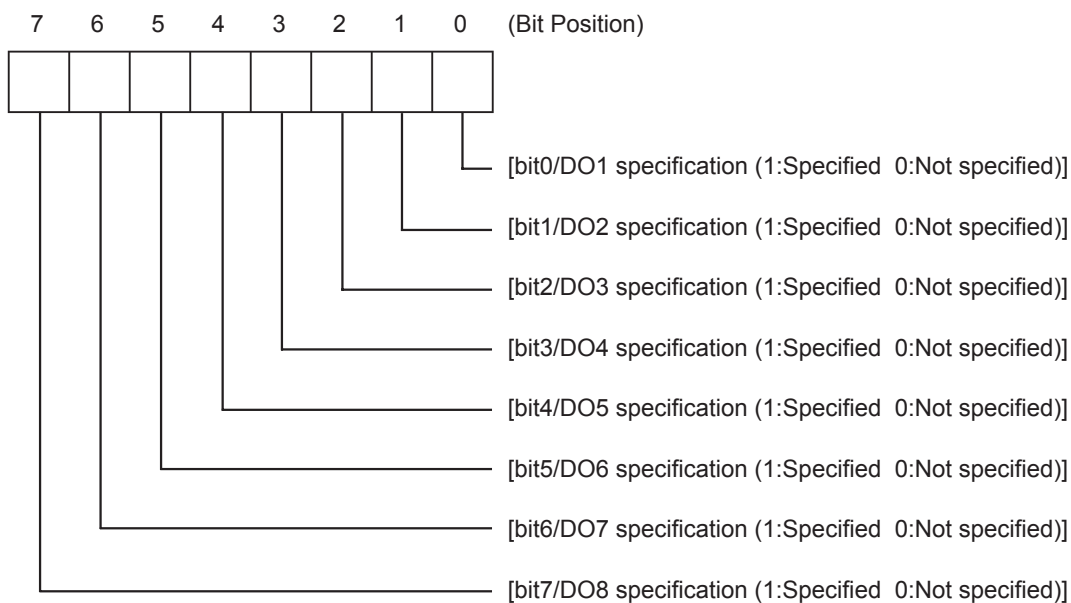

## 4.3 Output Setting

---

- **An example of use**

If you want to set “1” to the output of DO1 terminal when any one of the outputs of DO1, DO3, and DO5 are ON:

The DO1 output OR setting will be as follows:

**“DO1 Output logic operation OR” : 0001 0101b**  
**: 0015h**

After the above setting is performed, the value of DO1 terminal output will be “1” when any one of DO1, DO3 and DO5 are ON, and will be “0” when all of them are OFF.

DO1	DO3	DO5	DO1 terminal output value
ON	ON	ON	1
ON	ON	OFF	1
ON	OFF	ON	1
ON	OFF	OFF	1
OFF	ON	ON	1
OFF	ON	OFF	1
OFF	OFF	ON	1
OFF	OFF	OFF	0

## Output Scaling Base and Span Setting

Control

It is setting for adjusting the output value when the output type is the control output.

Each DO output has the parameter shown below:

Parameter	Range	Unit	Factory Default	Attribute	MODBUS Register Number (Relative Address)
DO1 scaling base to DO8 scaling base	-100.0 to 100.0	%	0.0	R / W	DO1:40409 (0198h)
					DO2:40423 (01A6h)
					DO3:40437 (01B4h)
					DO4:40451 (01C2h)
					DO5:40465 (01D0h)
					DO6:40479 (01DEh)
					DO7:40493 (01ECh)
					DO8:40507 (01FAh)
DO1 scaling span to DO8 scaling span	-100.0 to 100.0	%	100.0	R / W	DO1:40410 (0199h)
					DO2:40424 (01A7h)
					DO3:40438 (01B5h)
					DO4:40452 (01C3h)
					DO5:40466 (01D1h)
					DO6:40480 (01DFh)
					DO7:40494 (01EDh)
					DO8:40508 (01FBh)

The value that is set in "DO Scaling Base" is output as 0% from the terminal, and the output value is below the set value, the output will be 0%.

The value that is set in "DO Scaling Span" is output as 100% from the terminal, and the output value is over the set value, the output will be 100%.

For example, to scale the output value between -80% and 80%, set "-80%" to "DO Scaling Base," and set "80%" to "DO Scaling Span." Then, the output from -80% to 80% will be 0% to 100% as shown in the figure.

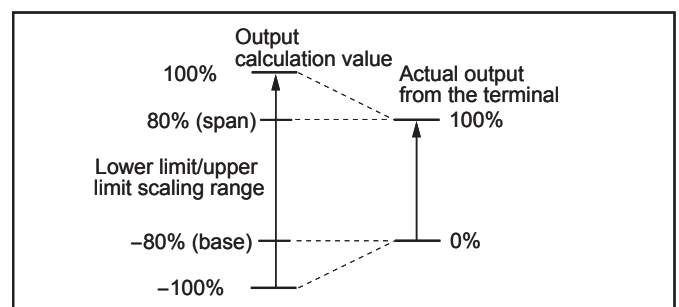

### Note

Make sure that the setting should be "DO Scaling Span Set value" > "DO Scaling Base Set value."

# DO Proportional Cycle

Control

It is for setting the proportional cycles for DO outputs.

**Point**

When the “Output Types”  is “1” (control output), the output signal alternates ON and OFF at a regular cycle. This ON and OFF cycle is referred to as the Proportional Cycle.

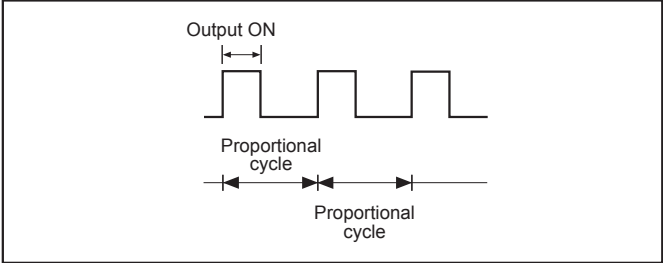

Each DO output has the parameter shown below:

Parameter	Range	Unit	Factory Default	Attribute	MODBUS Register Number (Relative Address)
DO1 Proportion cycle to DO8 Proportion cycle	1 to 120	second	30	R / W	DO1:40411 (019Ah)
					DO2:40425 (01A8h)
					DO3:40439 (01B6h)
					DO4:40453 (01C4h)
					DO5:40467 (01D2h)
					DO6:40481 (01E0h)
					DO7:40495 (01EEh)
					DO8:40509 (01FCh)

**Note**

To synchronize DO action when the proportional cycle is changed, reset this equipment (turn on the power again).

## Output Limit

Control

It is for setting the lower and upper limits of DO output, and for setting whether to output the value within the limit or without the limit when the output value reaches the limit value.

Each DO output has the parameter shown below:

Parameter	Range	Unit	Factory Default	Attribute	MODBUS Register Number (Relative Address)
DO1 Lower limits to DO8 Lower limits	0.0 to 100.0	%	0.0	R / W	DO1:40412 (019Bh)
					DO2:40426 (01A9h)
					DO3:40440 (01B7h)
					DO4:40454 (01C5h)
					DO5:40468 (01D3h)
					DO6:40482 (01E1h)
					DO7:40496 (01EFh)
					DO8:40510 (01FDh)
DO1 Upper limits to DO8 Upper limits	0.0 to 100.0	%	100.0	R / W	DO1:40413 (019Ch)
					DO2:40427 (01AAh)
					DO3:40441 (01B8h)
					DO4:40455 (01C6h)
					DO5:40469 (01D4h)
					DO6:40483 (01E2h)
					DO7:40497 (01F0h)
					DO8:40511 (01FEh)
DO1 Limit type to DO8 Limit type	0 to 3	None	0	R / W	DO1:40414 (019Dh)
					DO2:40428 (01ABh)
					DO3:40442 (01B9h)
					DO4:40456 (01C7h)
					DO5:40470 (01D5h)
					DO6:40484 (01E3h)
					DO7:40498 (01F1h)
					DO8:40512 (01FFh)

### Set values of DO Limit Type

Select the set value referring to the table below:

Set value	Lower limit	Upper limit
0	-3.0%	103.0%
1	Lower limit value	103.0%
2	-3.0%	Upper limit value
3	Lower limit value	Upper limit value

Depending on the setting, the control outputs will change as shown below:

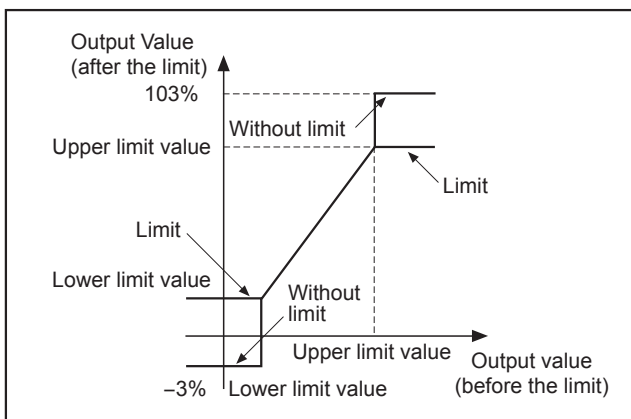

## Internal DO Area

Event

Control

It is for setting the value that is output from the DO area of the self-module without acquiring the DO output data from the control module.

It has the parameter shown below:

Parameter	Range	Unit	Factory Default	Attribute	MODBUS Register Number (Relative Address)
Internal DO data area 1 to Internal DO data area 16	During event output 0: OFF 1: ON	None	0	R / W	41001 (03E8h)
					41002 (03E9h)
					41003 (03EAh)
					41004 (03EBh)
					41005 (03ECh)
					41006 (03EDh)
					41007 (03EEh)
					41008 (03EFh)
	During control output 0.00 to 100.00	%			41009 (03F0h)
					41010 (03F1h)
					41011 (03F2h)
					41012 (03F3h)
					41013 (03F4h)
					41014 (03F5h)
					41015 (03F6h)
					41016 (03F7h)

By setting the output value in the internal DO area from PC and operation display through RS-485 communication, you can set the DO output at an arbitrary value.

### Note

- This function is valid when the master St. number is "0."
- When this equipment is turned off, the value that is set in the internal DO area will be reset to "0."

# Standby Output Set Value

Event Control

It is for setting the output value in the standby mode ▶▶ 4-5.

It has parameter shown below:

Parameter	Range	Unit	Factory Default	Attribute	MODBUS Register Number (Relative Address)
Standby mode setting	0: Output values while DI is running, and DO is in standby. 1: Output values while DI stops and DO is in standby	None	0	R / W	40270 (010Dh)
Standby output set value	0000h to FFFFh	None	0	R / W	40268 (010Bh)

## DI Standby Operation

- **When the “DI standby output set value” is “0”:**  
The DI input terminal state will be transferred as it is to the control module and PLC operation module.
- **When “DI standby output set value” is “1”:**  
All DI inputs will be “OFF,” and transferred to the control module and PLC operation module.

## DO Standby Operation

DO operations will differ depending on the output type that has been set in “Output Types” ▶▶ 4-17.

- **When the “Output Type” is “0” (event output):**  
The DO output value (0:OFF, 1:ON) that has been set in “Standby Output Set Value” will be output from the DO terminal.

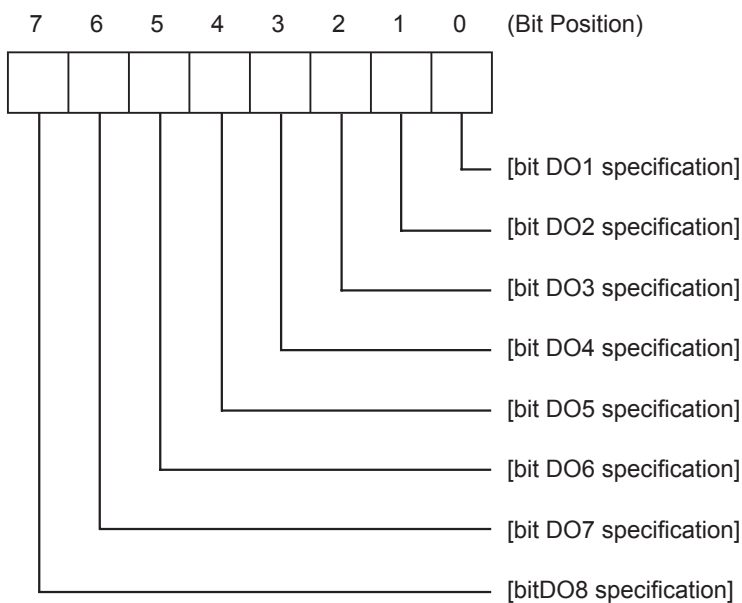

- **When the “Output Type” is “1” (control output):**  
All DO outputs will be 0% (OFF), and will be output from the DO terminal.



## FAULT Output 1 Set Value

Event

Control

It is for setting the output value when this equipment is in fault state (communication failure between control modules).

It has the parameter shown below:

Parameter	Range	Unit	Factory Default	Attribute	MODBUS Register Number (Relative Address)
FAULT OUT1 set value	0: HOLD 1: OFF	None	0	R / W	40260 (0103h)

### DI Operation during Fault

- When “FAULT OUT1 set value” is “0”:  
The DI input terminal will be held in the state before the fault occurred.
- When “FAULT OUT1 set value” is “1”:  
All DI input will be “OFF.”

### DO Operation during Fault

- When “FAULT OUT1 set value” is “0”:  
The DO output terminal will be held in the state before the fault occurred.
- When “FAULT OUT1 set value” is “1”:  
All DO output terminal will be “OFF.”



# 4.4 Communication Setting

## Communication Setting

The following communication settings can be performed on this equipment:

- RS-485 Communication Speed Setting and RS-485 Parity Setting [▶▶ 4-36](#)
- RS-485 Communication Permission Setting [▶▶ 4-36](#)
- Enhanced Communication Module (PUMC) Connection Permission [▶▶ 4-37](#)
- RS-485 Response Interval Time Setting [▶▶ 4-38](#)

## RS-485 Communication Speed Setting and RS-485 Parity Setting

It is for setting transmission speeds and parity checks of external communication using RS-485.

Each module has the parameter shown below:

Parameter	Range	Unit	Factory Default	Attribute	MODBUS Register Number (Relative Address)
RS-485 Communication speed	0 : (9.6kbps) 1 : (19.2kbps) 2 : (38.4kbps) 3 : No Setting 4 : (115.2kbps)	None	1	R / W	40115 (0072h)
RS-485 Parity setting	0 : (None) 1 : (Odd numbers) 2 : (Even numbers)	None	0	R / W	40111 (006Eh)

### Note

The communication speed and parity settings of the master and all slaves on the same communication system should be the same. If these settings are not the same, communication can not be performed.

## RS-485 Communication Permission Setting

It is for setting Read/Write permission of external communication using RS-485/loader communication.

Each module has the parameter shown below:

Parameter	Range	Unit	Factory Default	Attribute	MODBUS Register Number (Relative Address)
RS-485 Communication permission	0 : (Read only) 1 : (Read and Write permitted)	None	1	R / W	40114 (0071h)

### Note

Once "0 (Read only)" is set, parameters except for "RS-485 Communication permission" can not be changed (to Write). A response will be returned to Write, however, actual Write will not be performed.

## Enhanced Communication Module (PUMC) Connection Permission

It is for setting permission of inter-module communication when the enhanced communication module (PUMC) is connected.

Each module has the parameter shown below:

Parameter	Range	Unit	Factory Default	Attribute	MODBUS Register Number (Relative Address)
Enhanced communication module (PUMC) connection	0 : PUMC not connected (RS-485 Enable) 1 : PUMC connected (RS-485 Disable)	None	0	R / W	40116 (0073h)

### Note

- Even if “0: Without PUMC connection (RS-485 is valid)” is set to one of the multiple modules, this communication setting does not influence the settings of the modules after this module. The permission setting is valid only for the module to which the permission setting is given
- When enhanced communication module (PUMC) connection is “1: With PUMC connection (RS-485 is not valid),” RS-485 communication can not be performed.

## RS-485 Response Interval Time Setting

---

It is for setting response interval time of RS-485 communication.

**Point**

In RS-485 communication, transmitting and receiving are performed only on a single transmission line, therefore, switching between transmitting and receiving must be performed with precise timing. For this reason, response interval time must be set to secure the time after transmission of a host, that is a communication partner, is completed until the transmission line is switched to receiving.

The length of interval time should be set to suit a host that is a communication partner.

---

Each module has the parameter shown below:

Parameter	Range	Unit	Factory Default	Attribute	MODBUS Register Number (Relative Address)
RS-485 Response interval time	0 to 25	1 digit / 20ms	1	R / W	40113 (0070h)

**Note**

- Note that the response interval time is 20ms for every set value 1. The response interval time up to 500 ms can be set.
  - The response interval time setting for the master and all slaves on the same communication system must be the same.
-

---

# 4.5 Monitor

---

## Monitor

---

This equipment allows you to monitor operations by using the following monitoring functions:

- DO Calculated Result Monitor [▶▶ 4-40](#)
- DI Calculated Result Monitor [▶▶ 4-41](#)
- DI Terminal Monitor [▶▶ 4-42](#)
- System FAULT Status [▶▶ 4-43](#)
- LED Display and Setting [▶▶ 4-44](#)

## DO Calculated Result Monitor

It is for referring to the current output (DO calculated results) of this equipment.

It has the parameter shown below:

Parameter	Unit	Attribute	MODBUS Register Number (Relative Address)
Digital output calculated result monitor	None	R	31002 (03E9h)

ON/OFF of the DO calculated results are stored in the corresponding bit (ON= "1", OFF= "0").

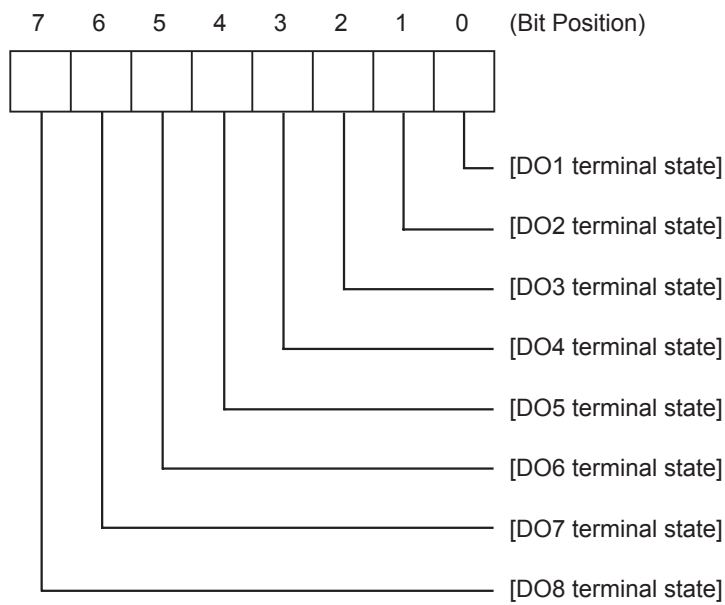



## DI Calculated Result Monitor

It is for referring to the current transfer output (DI input terminal calculated result) of this equipment.

It has the parameter shown below:

Parameter	Unit	Attribute	MODBUS Register Number (Relative Address)
Digital input calculated result monitor	None	R	31001 (03E8h)

Bit calculated results of the ON/OFF state of the DI terminals are stored in the corresponding bits. (ON= "1", OFF= "0").

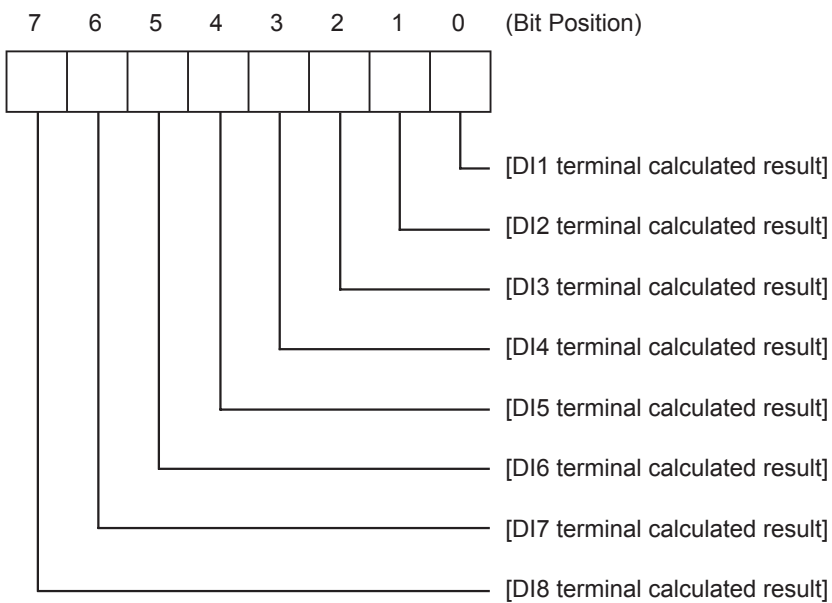

## DI Terminal Monitor

It is for referring to the current input state (DI input terminal) of this equipment.

It has the parameter shown below:

Parameter	Unit	Attribute	MODBUS Register Number (Relative Address)
Digital input terminal monitor	None	R	31003 (03EAh)

The ON/OFF state of DI terminals is stored in the corresponding bit (ON= "1", OFF= "0").

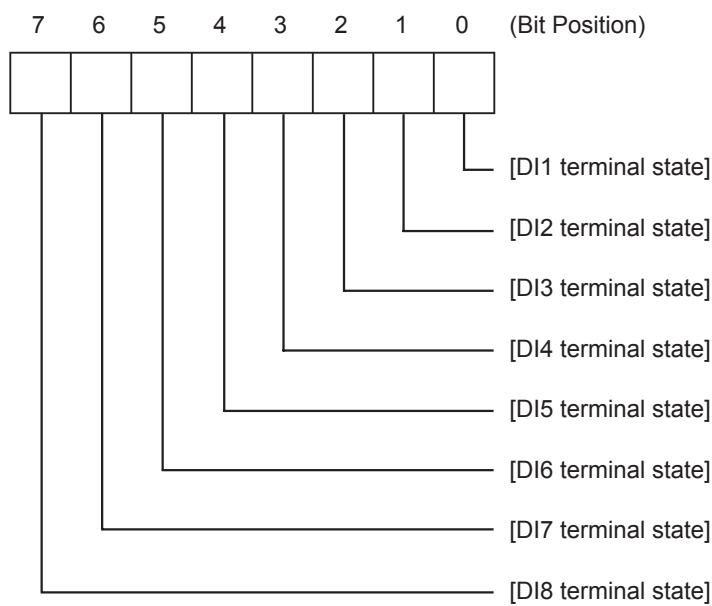

## System FAULT Status

It is for referring to the current communication status of this equipment.

It has the parameter shown below:

Parameter	Unit	Attribute	MODBUS Register Number (Relative Address)
System FAULT status	None	R	30064 (003Fh)

The communication status of this equipment is stored in the corresponding bit. If communication fault occurs, the corresponding bit will be "ON."

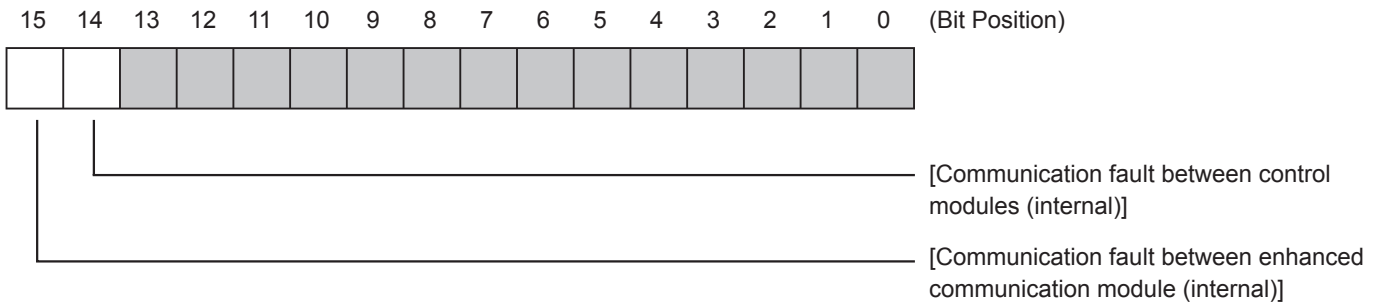

## LED Display and Setting

It is for setting the lighting conditions of the LED lamps on the front terminal block of this equipment.

It has the parameter shown below:

Parameter	Range	Unit	Factory Default	Attribute	MODBUS Register Number (Relative Address)
LED2 lamp allocation	0 : OFF 1 : RS-485 communication state 2 : Operation state	None	1	R / W	40222 (00DDh)

### LED Lamps

On the front terminal block, there are 18 LED lamps which are “PWR”, “COM”, “DI1 to DI8”, and “DO1 to DO8” which indicate the operation state of this equipment.

According to the state of this equipment, the lamps illuminate as shown below:

Operation State	LED lamp			
	PWR	COM	DI1 to DI8	DO1 to DO8
Running	Green light	The lamp illuminates according to the preset lighting condition.	These lamps illuminate while inputting.	These lamps illuminate while outputting.
Standby				
Communication fault				

\*1 When a communication fault occurs between control modules (internal)  4-43, data link to control modules is not performed.

### LED Lighting Condition Setting

Lighting conditions can be set to the “COM” lamp.

- “COM” Lamp Lighting Condition Setting

Lighting condition		LED color	Set value
RS485 communication state	While receiving	Green	1
	While transmitting	Orange	
Operation State	Running	Green	2
	Standby	Orange	

# 5

# Communication

5.1	Communication Functions .....	5-3
5.2	Communication Specifications .....	5-5
5.3	Connection.....	5-7
5.4	Setting Communication Parameters .....	5-10
5.5	Modbus RTU Communication Protocol.....	5-12
5.6	Command and Transmission Frame Details .....	5-20
5.7	Address Map and Data Format .....	5-29
5.8	Sample Program.....	5-39



# 5.1 Communication Functions

PUM is equipped with communication functions from the RS-485 interface and loader interface, which enables the transmission and reception of data between such devices as the personal computer, programmable controller, and graphic panel.

The communication system is composed of a master and slave relationship. Up to thirty-two slaves (PUMs) may be connected to one master (such as a personal computer) based on a “single master/multiple slave” method.

However, the master can only communicate with one slave at a time. Therefore, each slave is specified by the “Station No.” setting. With loader communication, only one slave can be connected to one master.

## Note

- Systems constructed with the PUM as slaves do not respond to messages issued by the master with broadcast queries where the station number is “0”.
- Communication with loader interface should not be attempted during production operation or during RS-485 communication.

In order to have proper communication between master and slave, the transmission data must be in the same format. This document explains how to transmit data using the Modbus RTU protocol format.

When using equipment with an RS-232C interface, such as a personal computer, as the master, make sure to use an RS-232C to RS-485 converter.

When using loader communication, you can use RS-232C communication with the personal computer by connecting the loader interface located on the main unit front face with the loader communication cable (model: PUMZ\*L01, optional).

[RS-232C to RS-485 converter] (Recommended)

Model number/Type	Manufacturer	Max. communication speed	URL
KS3C-10	Omron	38.4kbps	<a href="http://www.omron.co.jp">http://www.omron.co.jp</a>
RC-770X	Systemex RA	115.2kbps	<a href="http://www.systemex-ra.co.jp">http://www.systemex-ra.co.jp</a>

## Connecting to a Programmable Controller

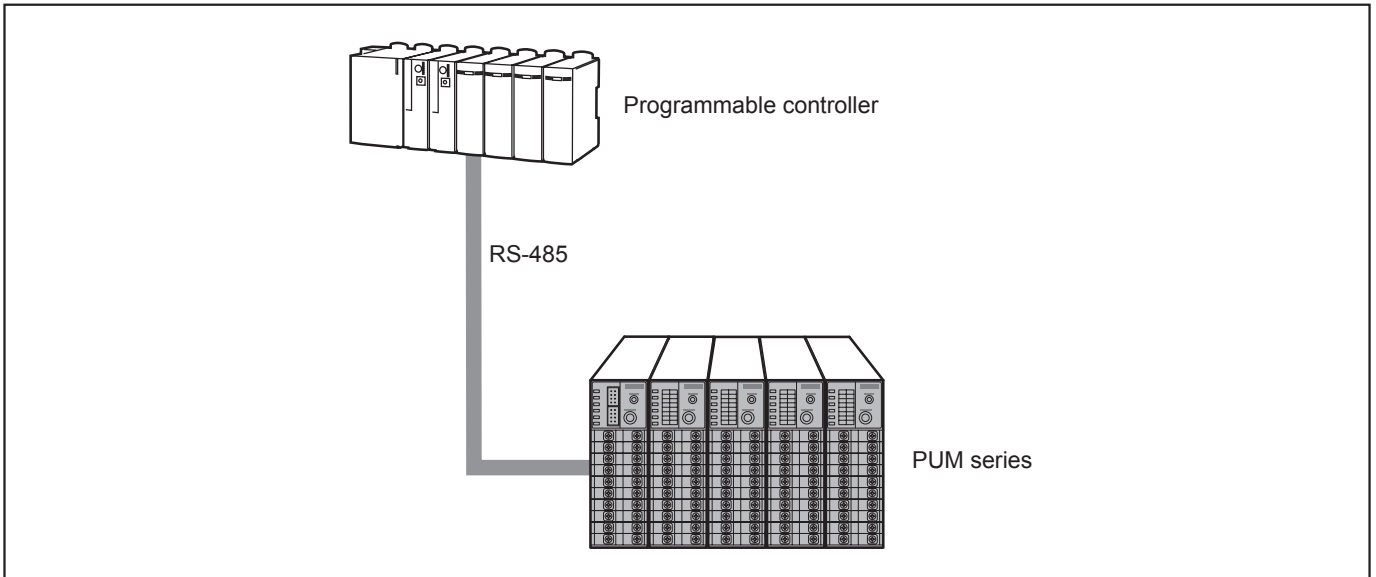

## Connecting to a Personal Computer

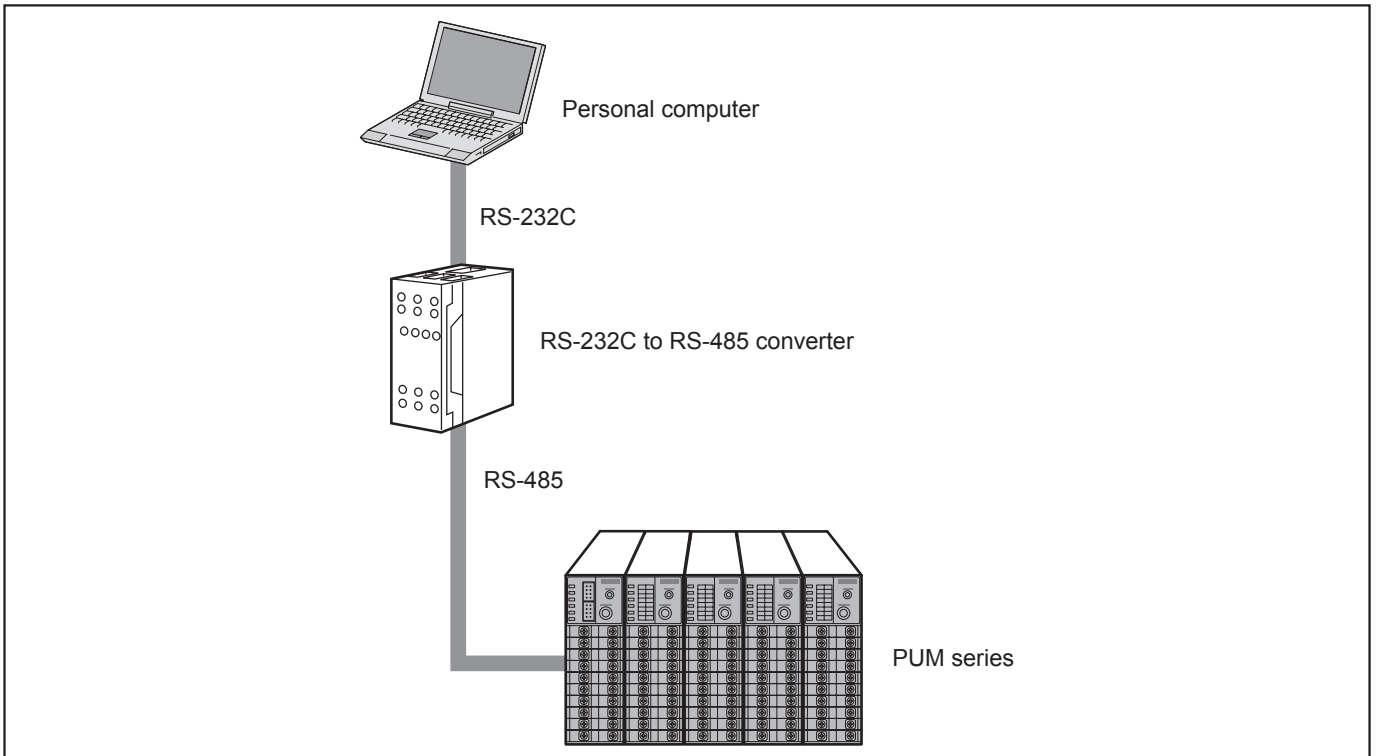

### Note

- When using the RS-232C to RS-485 converter, check to make sure that the cable is properly connected between the converter and master. Communication will not work properly if the connection is incorrect.
- Be sure to correctly set the communication settings (such as communication speed and parity) on the RS-232C to RS-485 converter. Communication will not work properly if the settings are incorrect.



# 5.2 Communication Specifications

## RS-485

Item	Specifications	
Electrical specifications	EIA RS-485 compliant	
Communication method	Two wire system, half duplex, serial	
Synchronous method	Asynchronous	
Connection status	1 : N	
Max. no. of connections	32 units	
Communication distance	Max 1000m (at 38.4kbps or less), Max 250m (at 115.2kbps)	
Communication speed	9.6kbps, 19.2kbps, 38.4kbps, 115.2kbps	
Data format	Data length	8 bits
	Stop bit	1 bit
	Parity	None/Even/Odd (Selectable)
Transmission code	HEX value (Modbus RTU mode)	
Error detection	CRC-16	
Insulation	No insulation with loader communication port. Functional insulation with any other input/output.	

## Loader Interface

Item	Specifications	
Electrical specifications	EIA RS232C	
Communication method	3-wire system, half duplex, serial	
Synchronous method	Asynchronous	
Connection status	1 : 1	
Station No.	17 to 32	
Communication speed	19.2kbps (Fixed)	
Data format	Data length	8 bits
	Stop bit	1 bit
	Parity	None (Fixed)
Transmission code	HEX value (Modbus RTU mode)	
Error detection	CRC-16	
Insulation	No insulation with RS-485. Functional insulation with any other input/output.	

# 5.3 Connection

## ⚠ Warning

❗ Do not turn on power until all of the wiring is completely finished.  
There is a risk of electrical shock or damage.

## Assignment of Communication Terminals

### RS-485 (terminals on base part)

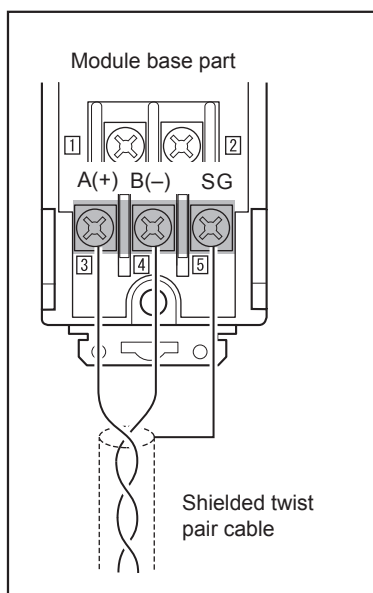

### Loader interface (terminals on front face)

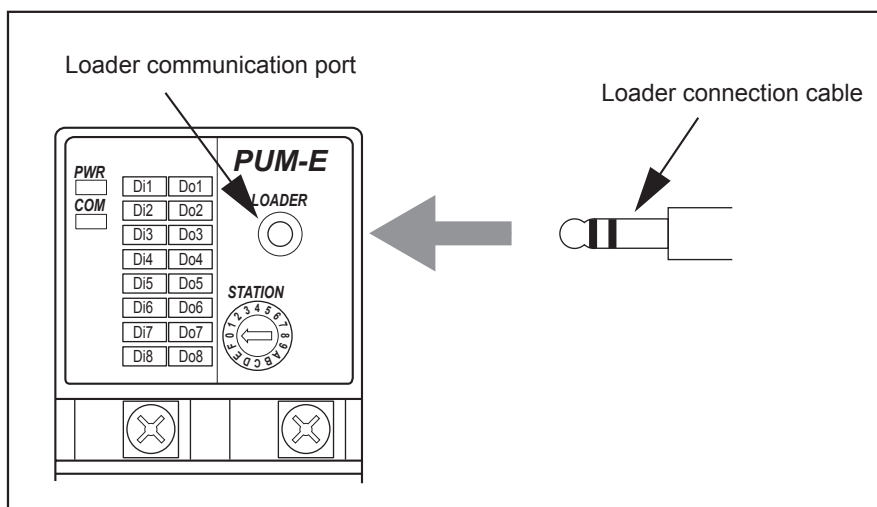

## Connection with RS-485

- Please use a shielded twist pair cable. (Recommended cable: KPEV-SB 0.5sq (made by The Furukawa Electric Co., Ltd.))
- The maximum cable length should be 1000m at 38.4kbps or less, 250m at 115.2kbps. One master and up to thirty-two PUMs (slaves) can be connected per circuit.
- Terminate both ends of the circuit with a terminating resistance of 100Ω (1/2W or more).
- Ground the shielded cable once towards the master side.

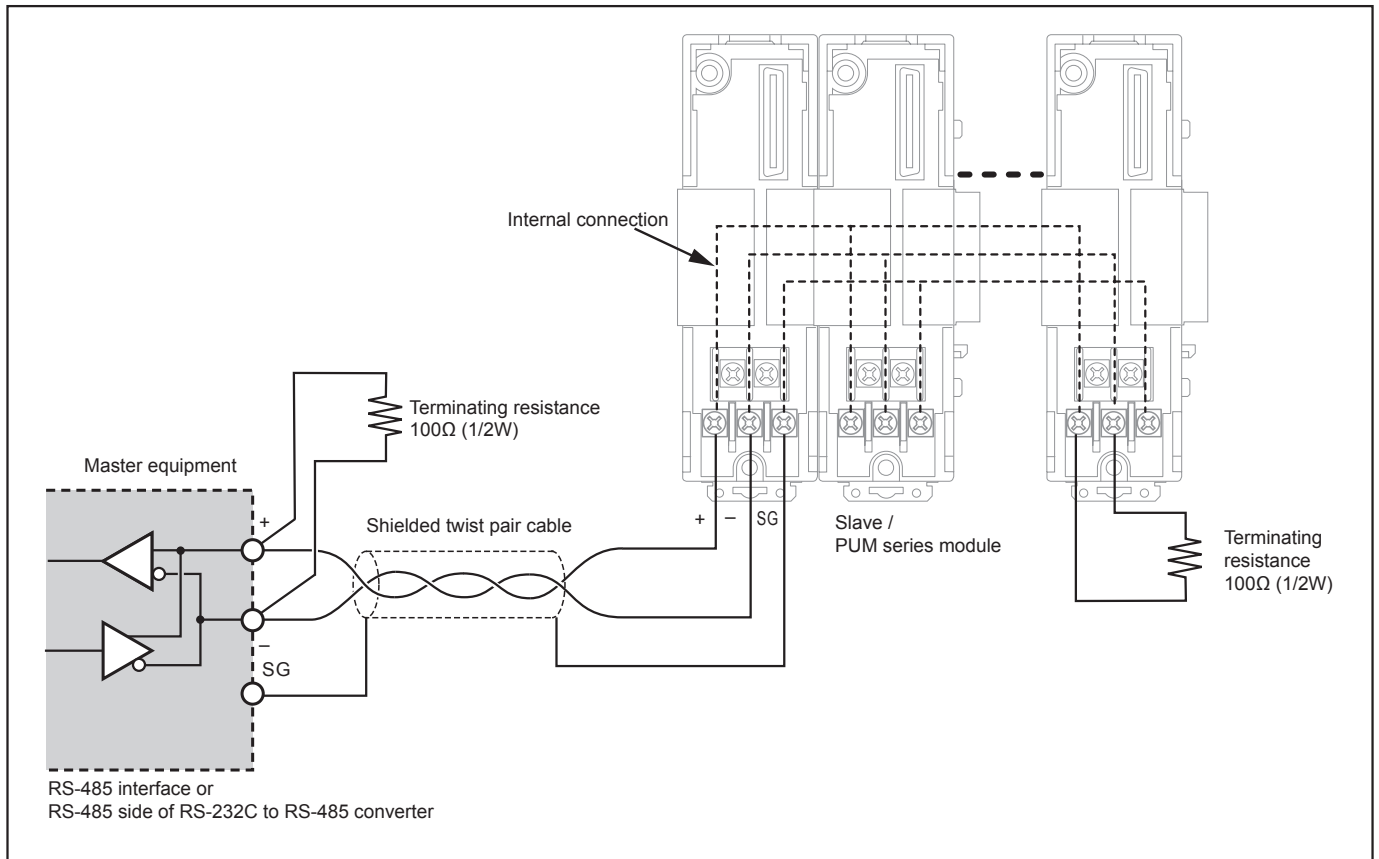

- SG does not have to be connected, but it can be used as an effective countermeasure against communication errors due to noise.
- If there are problems with EMC during communication, the noise level can be reduced by using a communication cable with a ferrite core.

Ferrite core (recommended):

For communication cable: H04SR211132 made by Seiwa Electric MFG. or equivalent

For power cable: E04SR241336A made by Seiwa Electric MFG. or equivalent

## Connection with Loader Interface

- Use the loader communication cable (RS-232C) sold separately.

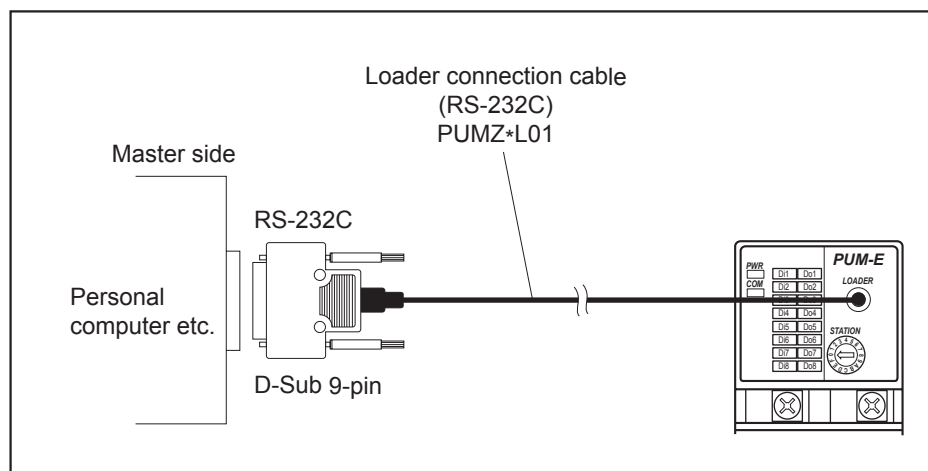

# 5.4 Setting Communication Parameters

The following settings are required for proper communication between the master and all slaves units (this equipment).

- The communication parameters for the master and all of the units must be set the same.
- All of the slaves on a circuit must be set with different “Station No.” other than “0 (zero)”. (Multiple PUMs must not have the same “Station No.”.)

## Setup Items for RS-485 (PUM Side)

Parameter (name)	Setup range	Factory default	Remarks
Station number	17 to 32	17	Set by the rotary switch located on the front face of the main unit. Setting value is [Rotary switch position + 17].
RS-485 Communication speed	0 (9.6kbps) 1 (19.2kbps) 2 (38.4kbps) 4 (115.2kbps)	1	“3” is forbidden.
RS-485 Parity setting	0 (None) 1 (Odd) 2 (Even)	0	
Data length	8 bits	–	Cannot be changed.
Stop bit	1 bit	–	Cannot be changed.
RS-485 Communication permission	0 : Read only 1 : Read/Write	1	
RS-485 Response interval time	0 to 25	1	The response interval time can be set by set value × 20 ms.
Enhanced communication module (PUMC) connection	0 : PUMC not connected (RS485 Enable) 1 : PUMC connected (RS485 Disable)	0	Set at “0” for use of RS-485 communication.

## Setup Items on Loader Interface (PUM Side)

Parameter (name)	Setup range	Factory default	Remarks
Station number	0 to Fh (17 to 32)	17	Set by the rotary switch located on the front face of the main unit. Setting value is [Rotary switch position + 17].
Communication speed	19.2kbps (fixed)	–	Cannot be changed.
Data length	8 bits	–	Cannot be changed.
Parity	None	–	Cannot be changed.
Stop bit	1 bit	–	Cannot be changed.
RS-485 Communication permission	0 : Read only 1 : Read/Write	1	

# 5.5 Modbus RTU Communication Protocol

---

---

The communication system with the MODBUS protocol always operates using a method where the master first sends a command message and the applicable slave replies with a response message.

The following describes the communication steps.

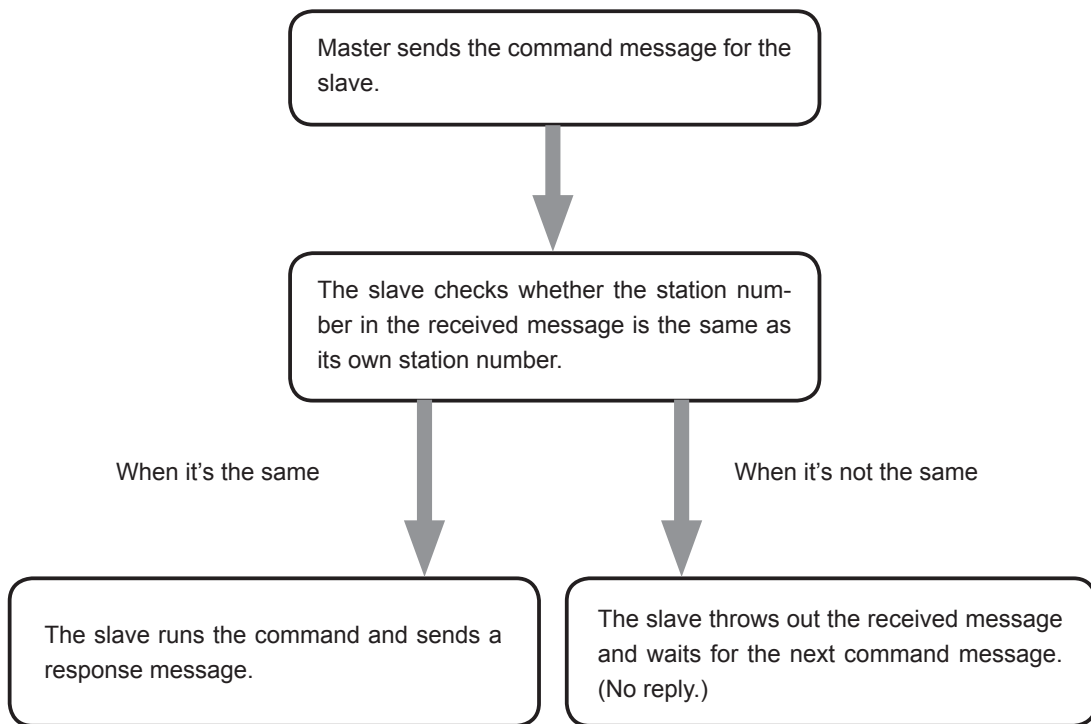

□



When the station number in the command message is the same as the unit's station number

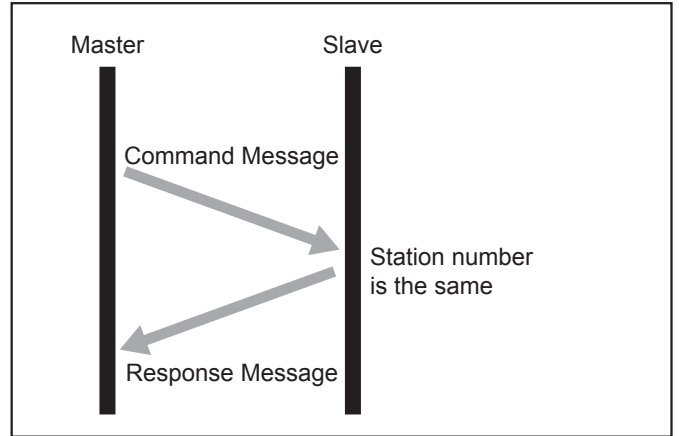

When the station number in the command message is not the same as the unit's station number

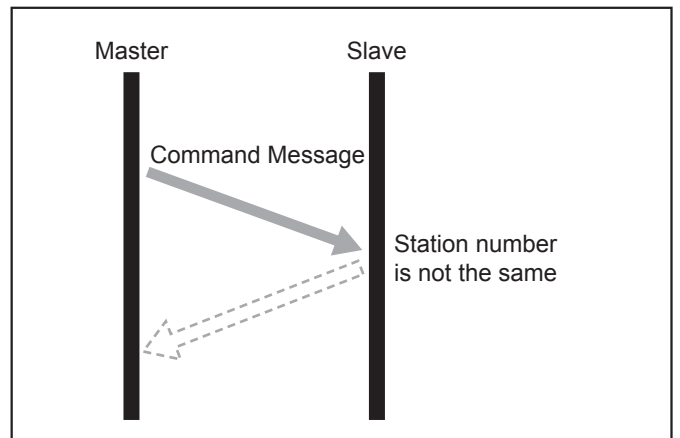

Point

The master can communicate with an individual slave when multiple slaves are connected on the same circuit by the station number specified in the master's command message.

## Message Composition

---

The command message and response message are composed of four parts: the station number, function code, data part, and error check code. These four parts are sent in that order.

Field name	Number of bytes
Station No.	1 byte
Function code	1 byte
Data part	2 to 64 bytes
Error check code (CRC-16)	2 bytes

### Station No.

This is the number specifying the slave. Commands can only be processed by slaves that have the same value set with the rotary switch (setting position + 17) located on the terminal block on the front face.

### Function Code

This code specifies the function for the slave to perform.

### Data Part

This data is required to run the function code. The composition of the data part is different depending on the function code.

The data in the PUM is assigned a coil number or register number. This coil number or register number is specified when the data is read or written through communication.

The coil number or register number used by the message employs a relative address.

The relative address is calculated using the following formula.

$\text{Relative address} = (\text{last 4 digits of the coil number or register number}) - 1$
--

(Ex.) When a function code specifies register number “40003”

$$\begin{aligned} \text{Relative address} &= (\text{the last four digits of 40003}) - 1 \\ &= 0002 \end{aligned}$$

is used in the message.

### Error Check Code

This code detects whether there are errors (changes in the bits) during the signal transmission processes. MODBUS protocol (RTU mode) uses CRC-16 (Cyclic Redundancy Check).

## Slave Response

### • Normal Slave Response

The slave creates and replies with a response message for each command message. The response message has the same format as the command message.

The contents of the data part are different depending on the function code.

### • Irregular Slave Response

If there are problems (such as specification of a nonexistent function code) with the contents of the command message other than transmission error, the slave creates and replies with an error response message without following the command.

The composition of the error response message uses the value of the function code in the command message plus 80H, as seen below.

Field name	Number of bytes
Station No.	1 byte
Function code + 80H	1 byte
Error code	1 byte
Error check code (CRC-16)	2 bytes

The error code is shown as follows.

Error Code	Contents	Explanation
01H	Faulty function code	A nonexistent function code was specified. Please check the function code.
02H	Faulty address for coil or register	The specified relative address for the coil number or register number cannot be used by the specified function code.
03H	Faulty coil number, register number or data limit.	The specified number is too large and specifies a range that does not contain coil numbers or register numbers. Furthermore, the specified data value is beyond the limit that is set in the specified parameter.
06H	Busy state	Data is being written to the internal memory. Wait 100 msec or more before retrying communication.

### • No Response

In the following situations, the slave will ignore the command message and not send a response message.

- The station number specified by the command message is not the same as the slave's specified station number.
- The error check code does not correspond, or a transmission error (such as parity error) is detected.
- The interval between the data comprising the message is empty for more than 24 bit time.

**Function Code**

For MODBUS protocol, coil numbers or register numbers are assigned by the function code, and each function code only works for the assigned coil number or register number.

The correspondence between the function code and the coil number or register number is as follows.

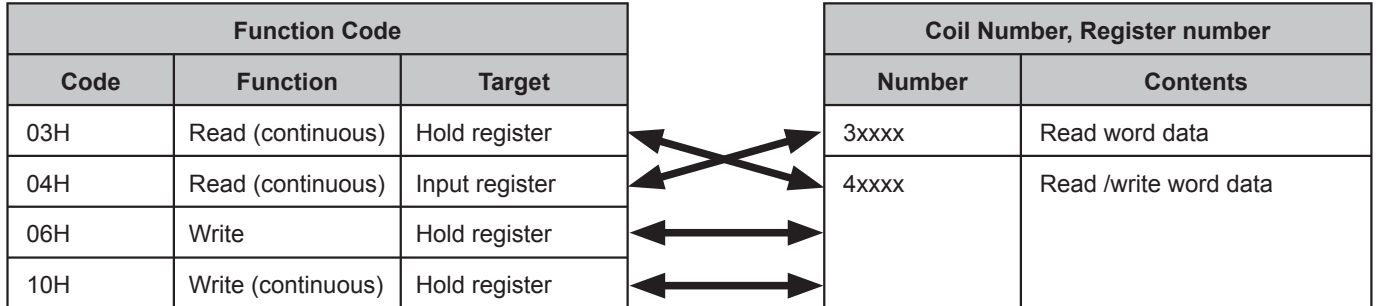

The message length for each function is as follows.

Code	Contents	Assignable Data Number	Command Message		Response Message	
			Minimum	Maximum	Minimum	Maximum
03H	Read word data	32 words *	8 bytes	8 bytes	7 bytes	69 bytes
04H	Read word data (Read only)	32 words *	8 bytes	8 bytes	7 bytes	69 bytes
06H	Write word data	1 word	8 bytes	8 bytes	8 bytes	8 bytes
10H	Continuously write word data	32 words *	11 bytes	73 bytes	8 bytes	8 bytes

\* : "Assignable Data Number" above is limited by the data number that the PUM assigned to the coil number or register number. (Excluding function code 06H).

## Calculating Error Check Code (CRC-16)

CRC-16 is a 2-byte (16-bit) error check code. The calculation range extends from the start of the message (station number) to the end of the data part.

The slave calculates the CRC of the received message and ignores the message if this value is not the same as the received CRC code.

CRC-16 is calculated as follows.

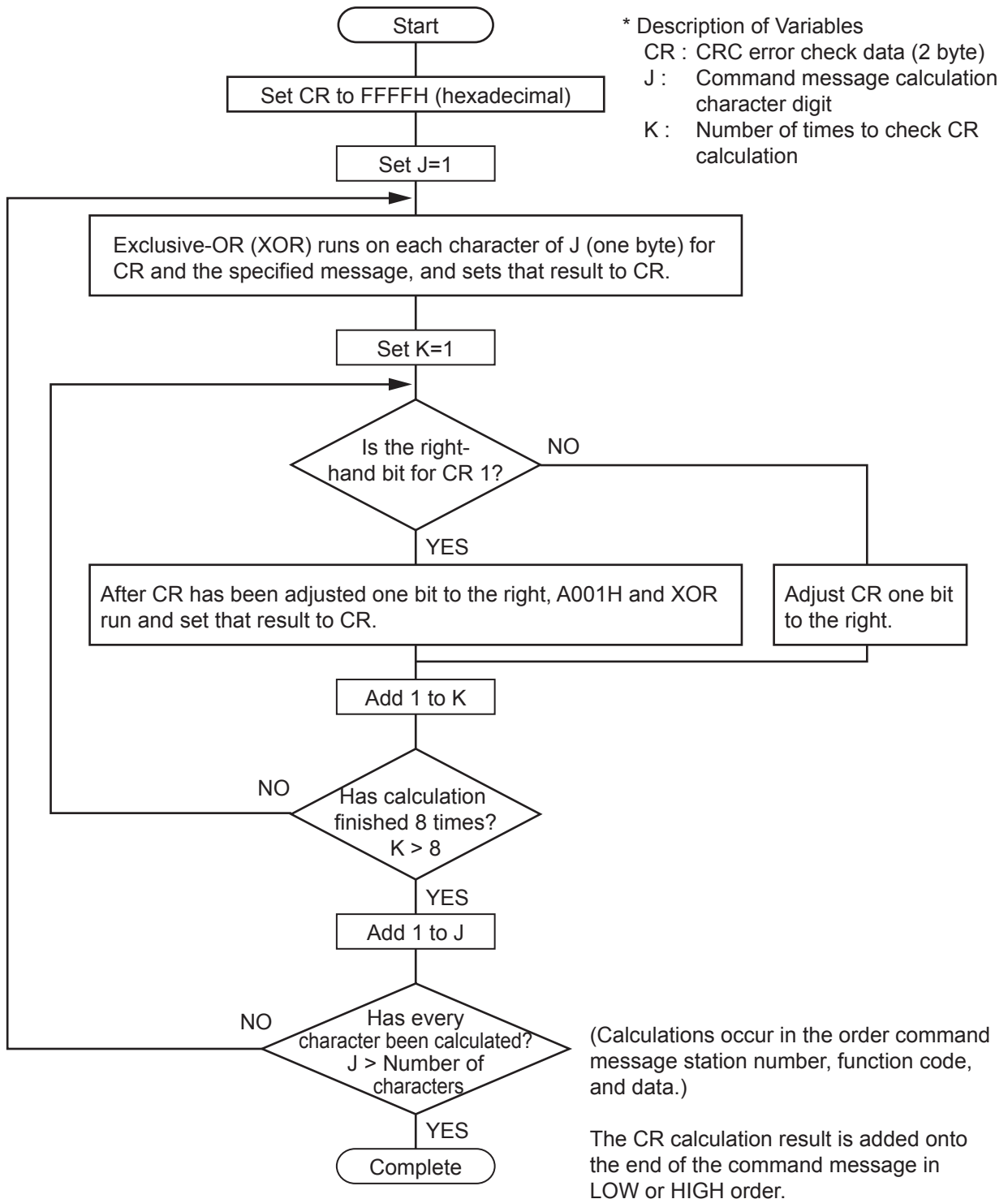

## Transmission Control Steps

---

### Master Communication Method

Start communication from the master while following the rules below.

1. The command message, must be sent after an empty space of at least 48 bit time.
2. The interval between each byte in a command message should be less than 24 bit time.
3. After sending a command message, for less than 24 bit time the master will enter receiving standby.
4. After receiving the response message, the next command message must be sent after at least 48 bit time. (Similar to 1 above.)
5. For safety reasons, create a framework where the master checks the response message, and if there is no response or an error occurs, retry at least three times.

#### Note

The definitions written above are for the minimum required value. For safety reasons, we recommend creating a master side program that keeps margins two to three times as large. For a concrete example, with 19.2kbps, we recommend programming a blank state (1 above) of at least 10ms, and the interval between bytes (2 above) and switching time from sending to receiving (3 above) within 1ms.

---

### Frame Detection

This communication system uses a two-wire RS-485 interface, and the circuit can therefore enter one of the following two states.

- Empty state (no data on the circuit)
- Communication state (data running on the circuit)

The units connected on the circuit start in receiving state and monitor the circuit. When a blank state appears on the circuit for at least 24 bit time, the unit detects the end of the previous frame, and within the next 24 bit time, enters receiving standby. When data appears on the circuit, the unit begins receiving data, and once another blank state of at least 24 bit time is detected, that frame is ended. In other words, the data on the circuit from the first time that a 24 bit time blank state appears to the second time one appears is loaded as one frame (a bundle of data). Therefore, one frame (command message) must be sent while following the rules below.

- Before sending the command message, leave an empty space of at least 48 bit time.
- The interval between each byte in a command message should be less than 24 bit time.

## PUM Response

After the PUM detects the frame (detects blank states at least 24 bit time long), that frame is used to send a command message. When a command message is sent locally, the response message is returned, but the processing time is about 1 to 30ms. (The time may change depending on the contents of the command message. ) Therefore, one frame (command message) must be sent while following the rules below.

- After sending a command message, for less than 24 seconds the master will enter receiving standby.

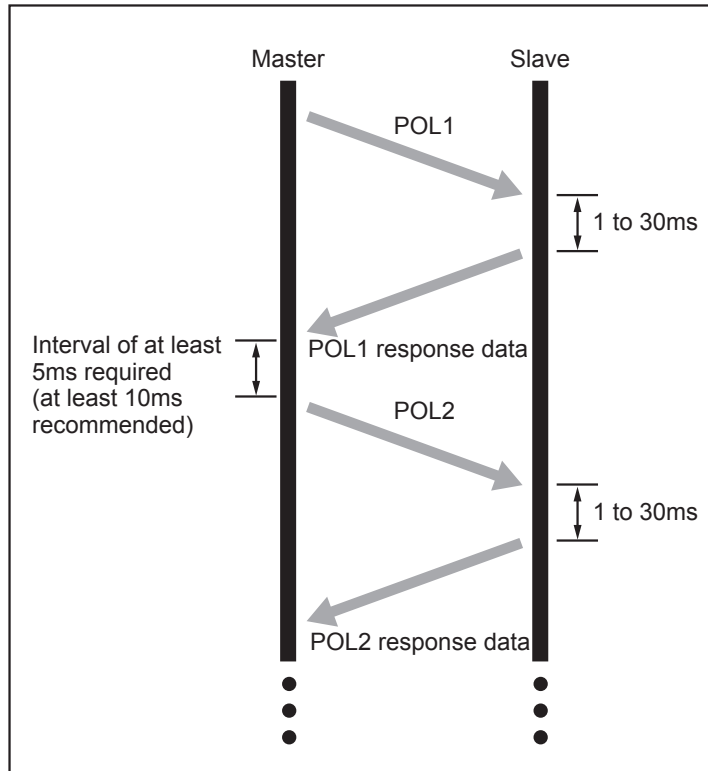

# 5.6 Command and Transmission Frame Details

---

## Reading Data

---

### Reading Word Data (Function Code: 03H)

The unit reads word data continuously for the specified number of words from the first number to start reading from.

The slave forwards the read word data from the upper number of bytes to the lower number.

Function code	03H
Max. No. of words to read in one message	32
Relative address	0014H to 03F7H
Register number	40021 to 41016



• Message Composition

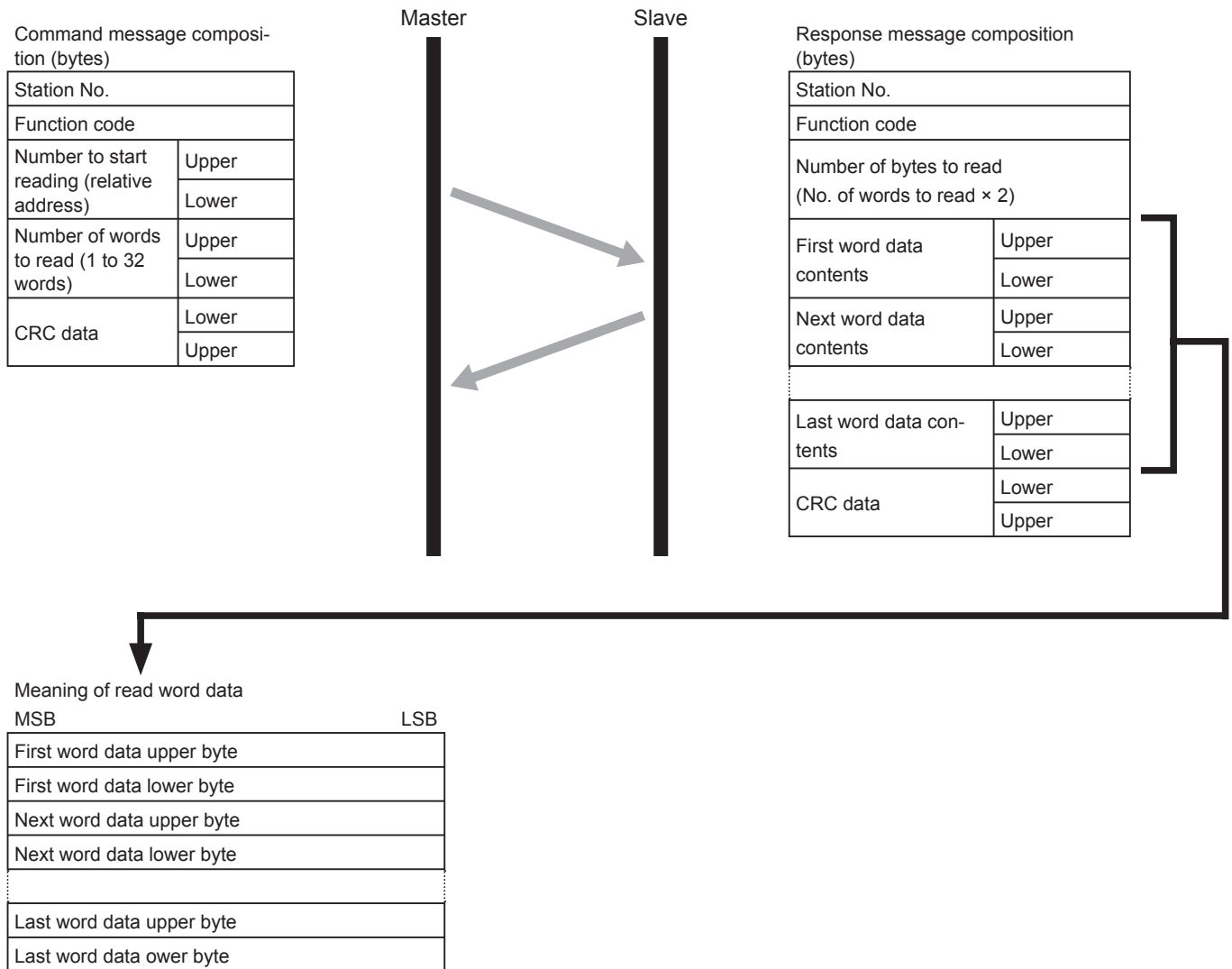

## 5.6 Command and Transmission Frame Details

- **Example of Transmitting a Message**

The message composition is as shown below in case of readout of “DO1 master module St. No.” and “DO1 master module Ch. No.” from station number 17.

- **Relative address of “Station number of DO1 master module” : 0191H, Number of data : 02H**

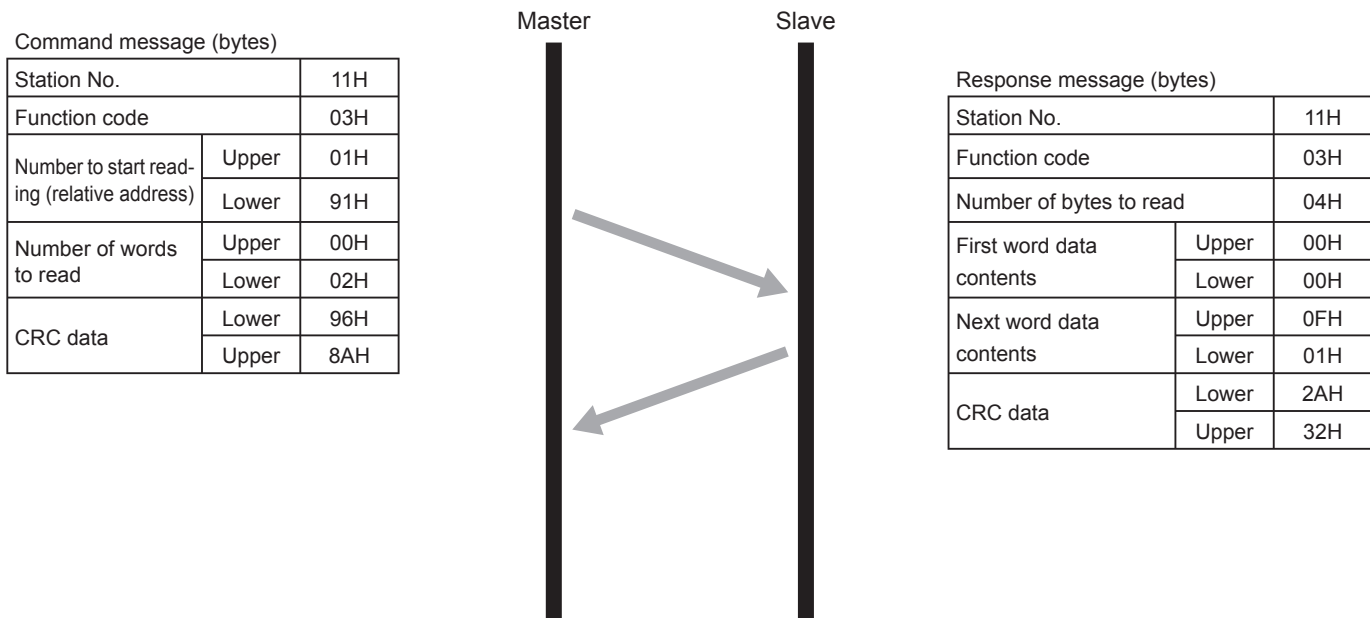

**Reading Read-Only Word Data (Function Code: 04H)**

The unit reads word data continuously for the specified number of words from the first number to start reading from. The slave forwards the read word data from the upper number of bytes to the lower number.

Function code	04H
Max. number of words to read in one message	32
Relative address	003FH to 03EAH
Register number	30064 to 31003

• **Message Composition**

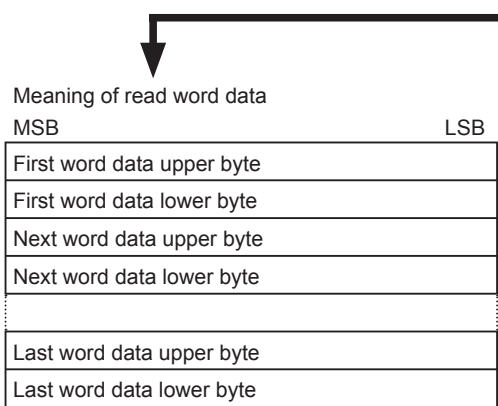
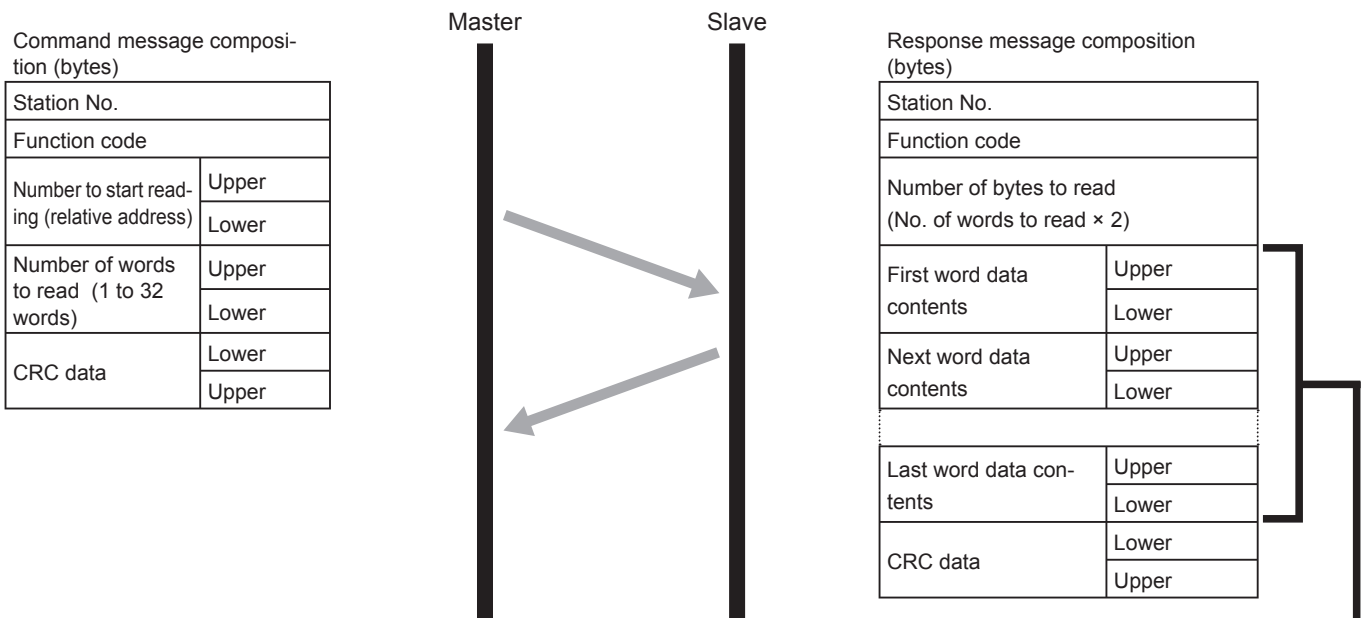

## 5.6 Command and Transmission Frame Details

- **Example of Transmitting a Message**

The message composition is as shown below in case of readout of “DI terminal monitor” from station number 17.

- **Relative address of “DI terminal monitor” : 03EAH, Number of data: 01H**

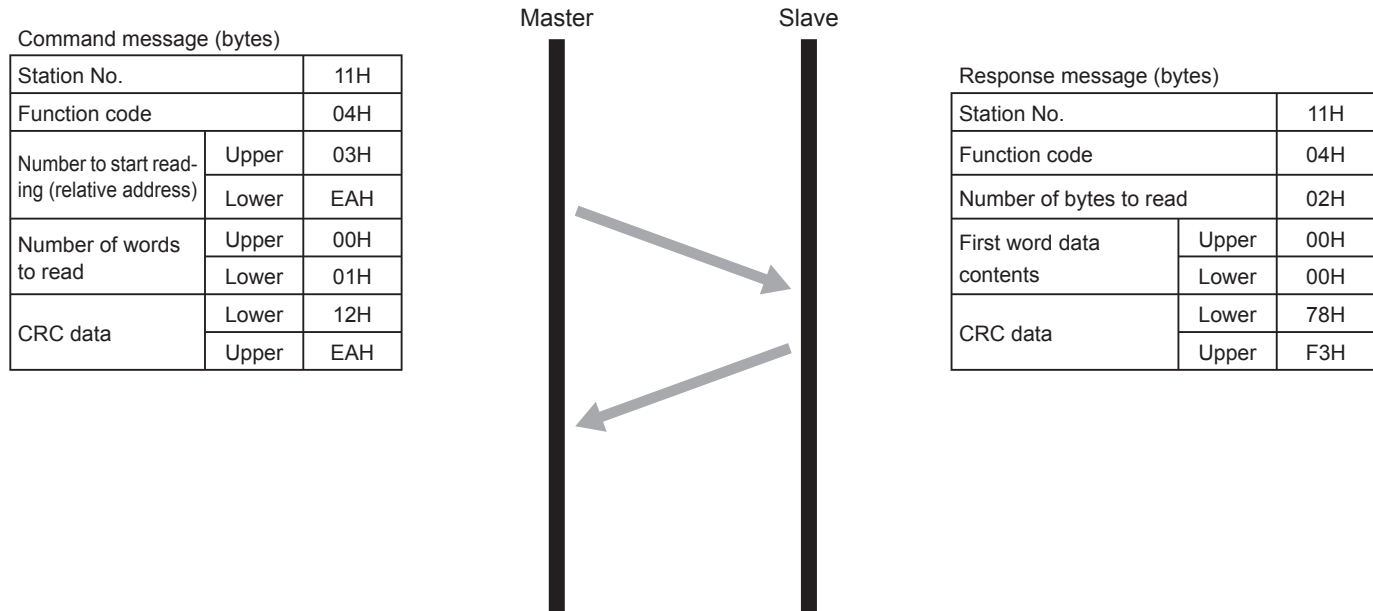

### Meaning of Read Data

Word data contents 0000H = 0

DI terminal monitor = 0

## Writing Data

### Writing Word Data (1 word, function code: 06H)

This writes the specified data to the specified number for word data. The master sends the data to be written from the upper number of bytes to the lower number.

Function code	06H
Max. number of words to read in one message	1
Relative address	0014H to 03F7H
Register number	40021 to 41016

#### Caution

Do not write data to a address (register number) that is not described in MODBUS address map. (It may cause the malfunction.)

#### • Message Composition

Command message composition (bytes)

Station No.	
Function code	
Specified write number (relative address)	Upper
	Lower
Word data to write	Upper
	Lower
CRC data	Lower
	Upper

Master

Slave

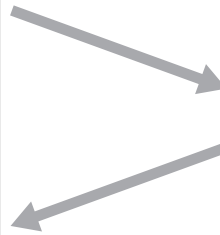

Response message composition (bytes)

Station No.	
Function code	
Specified write number (relative address)	Upper
	Lower
Word data to write	Upper
	Lower
CRC data	Lower
	Upper

• **Example of Transmitting a Message**

The case where “DO1 proportional cycle” of station number 17 is set as 120 (120D=0078H) is explained below as an example.

- **Relative address of “DO1 proportional cycle” : 019AH**

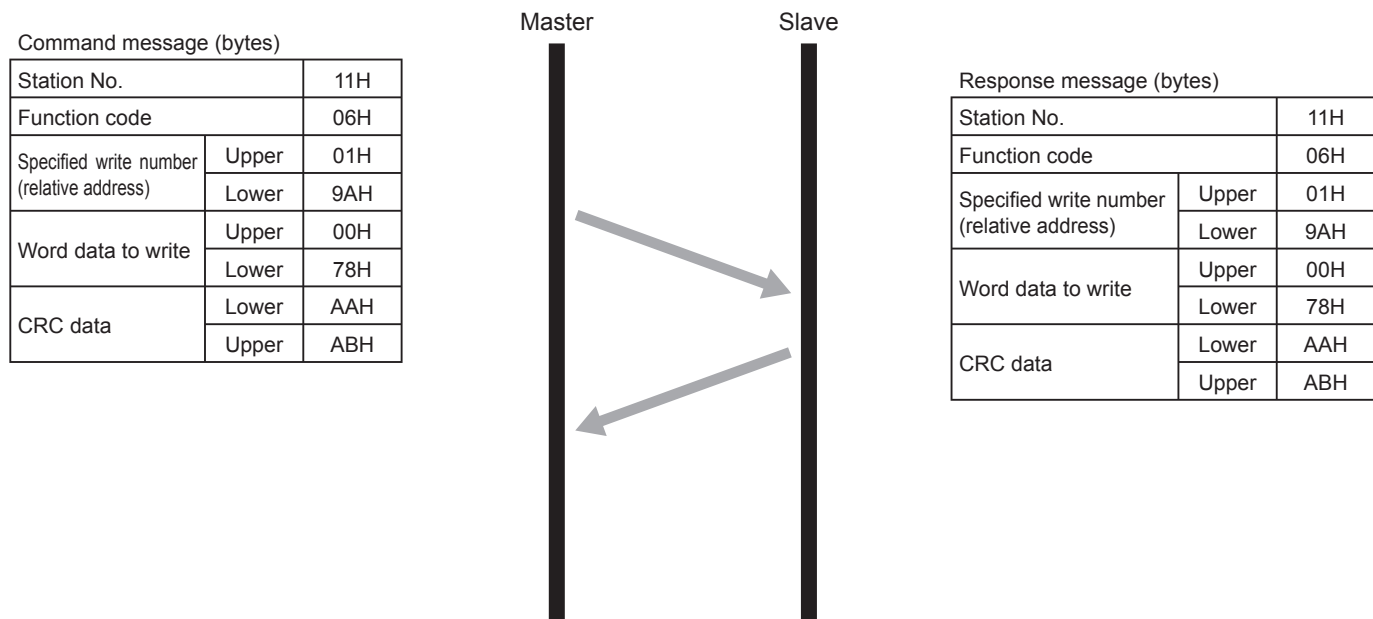

**Writing Continuous Word Data (function code: 10H)**

This writes continuous word information for a number of written words from the first number for writing.

The master sends the data to be written from the upper number of bytes to the lower number.

Function code	10H
Max. number of words to read in one message	32
Relative address	0014H to 03F7H
Register number	40021 to 41016

**Caution**

Do not write data to a address (register number) that is not described in MODBUS address map. (It may cause the malfunction.)

• **Message Composition**

Command message composition (bytes)

Station No.	
Function code	
Number to start writing (relative address)	Upper
	Lower
Number of words to write	Upper
	Lower
Number of bytes to write	
First word data to write	Upper
	Lower
Next word data to write	Upper
	Lower
.....	
Last word data to write	Upper
	Lower
CRC data	Lower
	Upper

} 1 to 32  
 } Number of words to write × 2

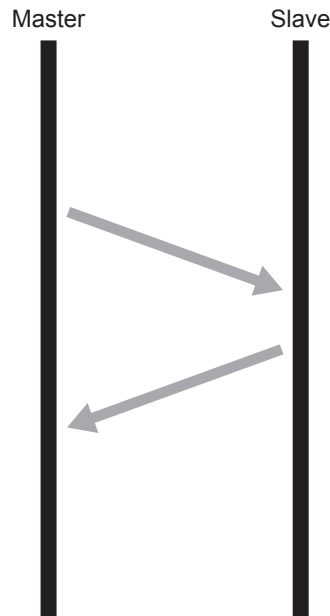

Response message composition (bytes)

Station No.	
Function code	
Number to start writing (relative address)	Upper
	Lower
Number of words to write	Upper
	Lower
CRC data	
Upper	

## 5.6 Command and Transmission Frame Details

### • Example of Transmitting a Message

The message composition is as follows in case of write of “RS-485 Response interval time”, “RS-485 communication Permission” and “RS-485 Communication speed” of station number 17.

RS-485 Response interval time = 25 (25D = 0019H)  
 RS-485 Communication permission = 1 (1D = 0001H)  
 RS-485 Communication speed = 4 (4D = 0004H)

- **Relative address of “RS-485 Response interval time”: 0070H, Number of data: 03H**

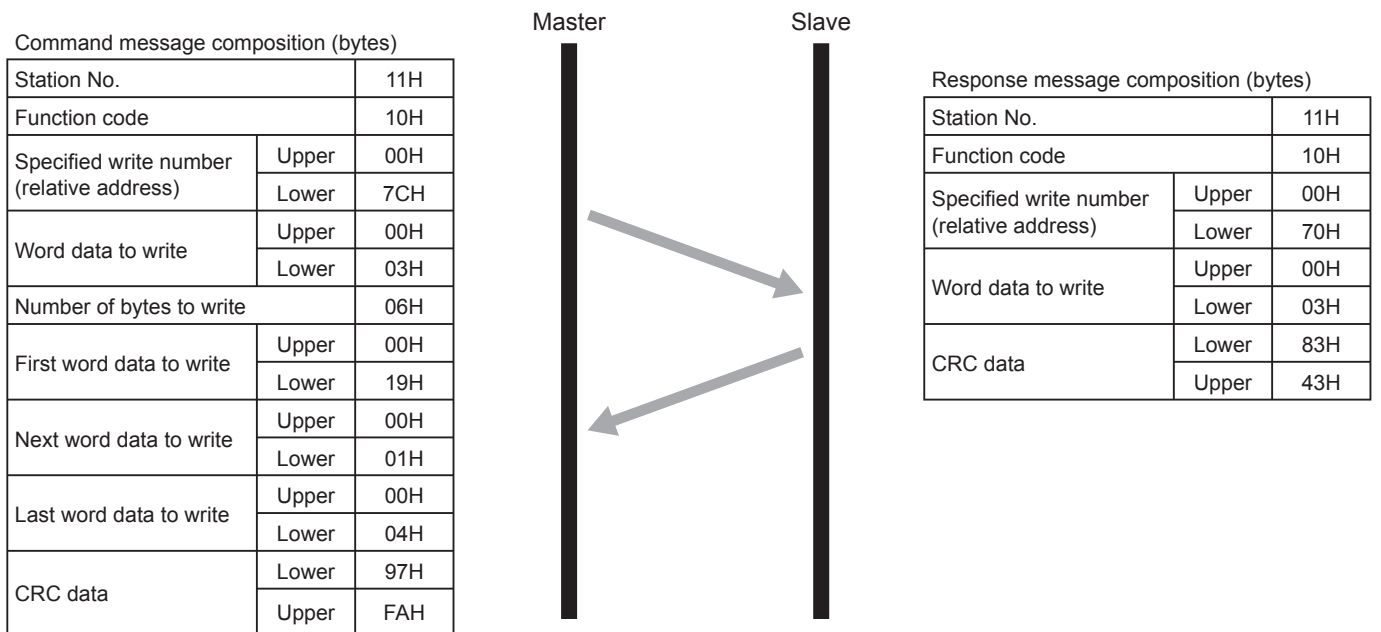

#### Point

The decimal point cannot be included in transmission data, so data such as [100.0] is transmitted as [1000].



# 5.7 Address Map and Data Format

Register No. of the Event I/O module's parameters are shown in the following table.

## Operation Parameters

Content	Readout/write data setting range	Factory-set value	Register No.
Run /Standby switch	0: RUN 1: Standby	0	40021
Digital input latch releases command	0: oFF 1: Release latch	0	40022
Digital output latch releases command	0: oFF 1: Release latch	0	40023

## Digital Input Parameters

Content	Readout/write data setting range	Factory-set value	Register No.
D11 Input option	Bit 0 : LATCH Bit 1 : NOT Bit 2 : AND Bit 3 : OR	0	40701
D11 Input logic operation AND	0 to 00FF	0	40703
D11 Input logic operation OR	0 to 00FF	0	40704
D12 Input option	0 to 15	0	40705
D12 Input logic operation AND	0 to 00FF	0	40707
D12 Input logic operation OR	0 to 00FF	0	40708
D13 Input option	0 to 15	0	40709
D13 Input logic operation AND	0 to 00FF	0	40711
D13 Input logic operation OR	0 to 00FF	0	40712
D14 Input option	0 to 15	0	40713
D14 Input logic operation AND	0 to 00FF	0	40715
D14 Input logic operation OR	0 to 00FF	0	40716
D15 Input option	0 to 15	0	40717
D15 Input logic operation AND	0 to 00FF	0	40719
D15 Input logic operation OR	0 to 00FF	0	40720
D16 Input option	0 to 15	0	40721
D16 Input logic operation AND	0 to 00FF	0	40723
D16 Input logic operation OR	0 to 00FF	0	40724
D17 Input option	0 to 15	0	40725
D17 Input logic operation AND	0 to 00FF	0	40727
D17 Input logic operation OR	0 to 00FF	0	40728
D18 Input option	0 to 15	0	40729
D18 Input logic operation AND	0 to 00FF	0	40731
D18 Input logic operation OR	0 to 00FF	0	40732

## Digital Output Parameters

Content	Readout/write data setting range	Factory-set value	Register No.
DO1 Output type	0: Event output 1: Control output	0	40401
DO1 Master module Station No.	0 to 255	0	40402
DO1 Master module Channel No.	1 to 4	1	40403
DO1 BIT position	0 to 00FF	1	40404
DO1 Output option	Bit 0 : LATCH Bit 1 : NOT Bit 2 : AND Bit 3 : OR	0	40405
DO1 Output logic operation AND	0 to 00FF	0	40407
DO1 Output logic operation OR	0 to 00FF	0	40408
DO1 Scaling base	-100.0 to +100.0	0	40409
DO1 Scaling span	-100.0 to +100.0	1000	40410
DO1 Proportion cycle	1 to 120	30	40411
DO1 Lower limits	0.0 to 100.0	0	40412
DO1 Upper limits	0.0 to 100.0	1000	40413
DO1 Limit type	0: Lower limit -3%, Upper limit 103% 1: Lower limit, Upper limit 103% 2: Lower limit -3%, Upper limit 3: Lower limit, Upper limit	0	40414
DO2 Output type	0: Event output 1: Control output	0	40415
DO2 Master module Station No.	0 to 255	0	40416
DO2 Master module Channel No.	1 to 4	1	40417
DO2 BIT position	0 to 00FF	2	40418
DO2 Output option	0 to 15	0	40419
DO2 Output logic operation AND	0 to 00FF	0	40421
DO2 Output logic operation OR	0 to 00FF	0	40422
DO2 Scaling base	-100.0 to +100.0	0	40423
DO2 Scaling span	-100.0 to +100.0	1000	40424
DO2 Proportion cycle	1 to 120	30	40425
DO2 Lower limits	0.0 to 100.0	0	40426
DO2 Upper limits	0.0 to 100.0	1000	40427
DO2 Limit type	0 to 3	0	40428
DO3 Output type	0: Event output 1: Control output	0	40429
DO3 Master module Station No.	0 to 255	0	40430
DO3 Master module Channel No.	1 to 4	1	40431
DO3 BIT position	0 to 00FF	4	40432
DO3 Output option	0 to 15	0	40433
DO3 Output logic operation AND	0 to 00FF	0	40435
DO3 Output logic operation OR	0 to 00FF	0	40436

## 5.7 Address Map and Data Format

Content	Readout/write data setting range	Factory-set value	Register No.
DO3 Scaling base	-100.0 to +100.0	0	40437
DO3 Scaling span	-100.0 to +100.0	1000	40438
DO3 Proportion cycle	1 to 120	30	40439
DO3 Lower limits	0.0 to 100.0	0	40440
DO3 Upper limits	0.0 to 100.0	1000	40441
DO3 Limit type	0 to 3	0	40442
DO4 Output type	0: Event output 1: Control output	0	40443
DO4 Master module Station No.	0 to 255	0	40444
DO4 Master module Channel No.	1 to 4	1	40445
DO4 BIT position	0 to 00FF	8	40446
DO4 Output option	0 to 15	0	40447
DO4 Output logic operation AND	0 to 00FF	0	40449
DO4 Output logic operation OR	0 to 00FF	0	40450
DO4 Scaling base	-100.0 to +100.0	0	40451
DO4 Scaling span	-100.0 to +100.0	1000	40452
DO4 Proportion cycle	1 to 120	30	40453
DO4 Lower limits	0.0 to 100.0	0	40454
DO4 Upper limits	0.0 to 100.0	1000	40455
DO4 Limit type	0 to 3	0	40456
DO5 Output type	0: Event output 1: Control output	0	40457
DO5 Master module Station No.	0 to 255	0	40458
DO5 Master module Channel No.	1 to 4	1	40459
DO5 BIT position	0 to 00FF	16	40460
DO5 Output option	0 to 15	0	40461
DO5 Output logic operation AND	0 to 00FF	0	40463
DO5 Output logic operation OR	0 to 00FF	0	40464
DO5 Scaling base	-100.0 to +100.0	0	40465
DO5 Scaling span	-100.0 to +100.0	1000	40466
DO5 Proportion cycle	1 to 120	30	40467
DO5 Lower limits	0.0 to 100.0	0	40468
DO5 Upper limits	0.0 to 100.0	1000	40469
DO5 Limit type	0 to 3	0	40470
DO6 Output type	0: Event output 1: Control output	0	40471
DO6 Master module Station No.	0 to 255	0	40472
DO6 Master module Channel No.	1 to 4	1	40473
DO6 BIT position	0 to 00FF	0	40474
DO6 Output option	0 to 15	0	40475
DO6 Output logic operation AND	0 to 00FF	0	40477
DO6 Output logic operation OR	0 to 00FF	0	40478
DO6 Scaling base	-100.0 to +100.0	0	40479

Content	Readout/write data setting range	Factory-set value	Register No.
DO6 Scaling span	-100.0 to +100.0	1000	40480
DO6 Proportion cycle	1 to 120	30	40481
DO6 Lower limits	0.0 to 100.0	0	40482
DO6 Upper limits	0.0 to 100.0	1000	40483
DO6 Limit type	0 to 3	0	40484
DO7 Output type	0: Event output 1: Control output	0	40485
DO7 Master module Station No.	0 to 255	0	40486
DO7 Master module Channel No.	1 to 4	1	40487
DO7 BIT position	0 to 00FF	0	40488
DO7 Output option	0 to 15	0	40489
DO7 Output logic operation AND	0 to 00FF	0	40491
DO7 Output logic operation OR	0 to 00FF	0	40492
DO7 Scaling base	-100.0 to +100.0	0	40493
DO7 Scaling span	-100.0 to +100.0	1000	40494
DO7 Proportion cycle	1 to 120	30	40495
DO7 Lower limits	0.0 to 100.0	0	40496
DO7 Upper limits	0.0 to 100.0	1000	40497
DO7 Limit type	0 to 3	0	40498
DO8 Output type	0: Event output 1: Control output	0	40499
DO8 Master module Station No.	0 to 255	0	40500
DO8 Master module Channel No.	1 to 4	1	40501
DO8 BIT position	0 to 00FF	0	40502
DO8 Output option	0 to 15	0	40503
DO8 Output logic operation AND	0 to 00FF	0	40505
DO8 Output logic operation OR	0 to 00FF	0	40506
DO8 Scaling base	-100.0 to +100.0	0	40507
DO8 Scaling span	-100.0 to +100.0	1000	40508
DO8 Proportion cycle	1 to 120	1	40509
DO8 Lower limits	0.0 to 100.0	0	40510
DO8 Upper limits	0.0 to 100.0	1000	40511
DO8 Limit type	0 to 3	0	40512

## Communication Parameters

Content	Readout/write data setting range	Factory-set value	Register No.
RS-485 parity setting	0: NONE 1: ODD 2: EVEN	0	40111
RS-485 Response interval time	0 to 25 (1 digit/20ms)	1	40113
RS-485 Communication permission	0: Read only 1: Read/Write	1	40114
RS-485 Communication speed	0: 9.6kbps 1: 19.2kbps 2: 38.4kbps 3: Forbidden 4: 115.2kbps	1	40115
Enhanced communication module (PUMC) connection	0: PUMC not connected (RS-485 Enable) 1: PUMC connected (RS-485 Disable)	0	40116

## Configuration Parameters

Content	Readout/write data setting range	Factory-set value	Register No.
FAULT output set value	0: HOLD 1: OFF	0	40260
Standby output set value	0000 to FFFF	0	40268
Standby mode setting	0: DI = Input value DO = Standby output set value 1: DI = All OFF DO = Standby output set value	0	40270
LED2 Lamp allocation	0 to 2	1	40222

## Monitor Parameters

Content	Readout/write data setting range	Factory-set value	Register No.
Digital output calculated result monitor	0000 to FFFF		31002
Digital input calculated result monitor	0000 to FFFF		31001
Digital input terminal monitor	0000 to FFFF		31003

## Internal DO Data Area

Content	Readout/write data setting range	Factory-set value	Register No.
Internal DO data area1	Event output 1: ON 0: OFF Control output 0.00 to 100.00	0	41001
Internal DO data area2		0	41002
Internal DO data area3		0	41003
Internal DO data area4		0	41004
Internal DO data area5		0	41005
Internal DO data area6		0	41006
Internal DO data area7		0	41007
Internal DO data area8		0	41008
Internal DO data area9		0	41009
Internal DO data area10		0	41010
Internal DO data area11		0	41011
Internal DO data area12		0	41012
Internal DO data area13		0	41013
Internal DO data area14		0	41014
Internal DO data area15		0	41015
Internal DO data area16		0	41016

## Order of Register Numbers

Content	Register No.	Relative address
Run/Standby switch	40021	0014h
Digital input latch releases command	40022	0015h
Digital output latch releases command	40023	0016h
RS-485 Parity setting	40111	006Eh
RS-485 Response interval time	40113	0070h
RS-485 Communication permission	40114	0071h
RS-485 Communication speed	40115	0072h
Enhanced communication module (PUMC) connection	40116	0073h
LED2 Lamp allocation	40222	00DDh
FAULT output set value	40260	0103h
Standby output set value	40268	010Bh
Standby mode setting	40270	010Dh
DO1 Output type	40401	0190h
DO1 Master module Station No.	40402	0191h
DO1 Master module Channel No.	40403	0192h
DO1 BIT position	40404	0193h
DO1 Output option	40405	0194h
DO1 Output logic operation AND	40407	0196h
DO1 Output logic operation OR	40408	0197h
DO1 Scaling base	40409	0198h
DO1 Scaling span	40410	0199h
DO1 Proportion cycle	40411	019Ah
DO1 Lower limits	40412	019Bh
DO1 Upper limits	40413	019Ch
DO1 Limit type	40414	019Dh
DO2 Output type	40415	019Eh
DO2 Master module Station No.	40416	019Fh
DO2 Master module Channel No.	40417	01A0h
DO2 BIT position	40418	01A1h
DO2 Output option	40419	01A2h
DO2 Output logic operation AND	40421	01A4h

Content	Register No.	Relative address
DO2 Output logic operation OR	40422	01A5h
DO2 Scaling base	40423	01A6h
DO2 Scaling span	40424	01A7h
DO2 Proportion cycle	40425	01A8h
DO2 Lower limits	40426	01A9h
DO2 Upper limits	40427	01AAh
DO2 Limit type	40428	01ABh
DO3 Output type	40429	01ACh
DO3 Master module Station No.	40430	01ADh
DO3 Master module Channel No.	40431	01AEh
DO3 BIT position	40432	01AFh
DO3 Output option	40433	01B0h
DO3 Output logic operation AND	40435	01B2h
DO3 Output logic operation OR	40436	01B3h
DO3 Scaling base	40437	01B4h
DO3 Scaling span	40438	01B5h
DO3 Proportion cycle	40439	01B6h
DO3 Lower limits	40440	01B7h
DO3 Upper limits	40441	01B8h
DO3 Limit type	40442	01B9h
DO4 Output type	40443	01BAh
DO4 Master module Station No.	40444	01BBh
DO4 Master module Channel No.	40445	01BCh
DO4 BIT position	40446	01BDh
DO4 Output option	40447	01BEh
DO4 Output logic operation AND	40449	01C0h
DO4 Output logic operation OR	40450	01C1h
DO4 Scaling base	40451	01C2h
DO4 Scaling span	40452	01C3h
DO4 Proportion cycle	40453	01C4h
DO4 Lower limits	40454	01C5h
DO4 Upper limits	40455	01C6h
DO4 Limit type	40456	01C7h



Content	Register No.	Relative address
DO5 Output type	40457	01C8h
DO5 Master module Station No.	40458	01C9h
DO5 Master module Channel No.	40459	01CAh
DO5 BIT position	40460	01CBh
DO5 Output option	40461	01CCh
DO5 Output logic operation AND	40463	01CEh
DO5 Output logic operation OR	40464	01CFh
DO5 Scaling base	40465	01D0h
DO5 Scaling span	40466	01D1h
DO5 Proportion cycle	40467	01D2h
DO5 Lower limits	40468	01D3h
DO5 Upper limits	40469	01D4h
DO5 Limit type	40470	01D5h
DO6 Output type	40471	01D6h
DO6 Master module Station No.	40472	01D7h
DO6 Master module Channel No.	40473	01D8h
DO6 BIT position	40474	01D9h
DO6 Output option	40475	01DAh
DO6 Output logic operation AND	40477	01DCh
DO6 Output logic operation OR	40478	01DDh
DO6 Scaling base	40479	01DEh
DO6 Scaling span	40480	01DFh
DO6 Proportion cycle	40481	01E0h
DO6 Lower limits	40482	01E1h
DO6 Upper limits	40483	01E2h
DO6 Limit type	40484	01E3h
DO7 Output type	40485	01E4h
DO7 Master module Station No.	40486	01E5h
DO7 Master module Channel No.	40487	01E6h
DO7 BIT position	40488	01E7h
DO7 Output option	40489	01E8h
DO7 Output logic operation AND	40491	01EAh
DO7 Output logic operation OR	40492	01EBh
DO7 Scaling base	40493	01ECh

Content	Register No.	Relative address
DO7 Scaling span	40494	01EDh
DO7 Proportion cycle	40495	01EEh
DO7 Lower limits	40496	01EFh
DO7 Upper limits	40497	01F0h
DO7 Limit type	40498	01F1h
DO8 Output type	40499	01F2h
DO8 Master module Station No.	40500	01F3h
DO8 Master module Channel No.	40501	01F4h
DO8 BIT position	40502	01F5h
DO8 Output option	40503	01F6h
DO8 Output logic operation AND	40505	01F8h
DO8 Output logic operation OR	40506	01F9h
DO8 Scaling base	40507	01FAh
DO8 Scaling span	40508	01FBh
DO8 Proportion cycle	40509	01FCh
DO8 Lower limits	40510	01FDh
DO8 Upper limits	40511	01FEh
DO8 Limit type	40512	01FFh
DI1 Input option	40701	02BCh
DI1 Input logic operation AND	40703	02BEh
DI1 Input logic operation OR	40704	02BFh
DI2 Input option	40705	02C0h
DI2 Input logic operation AND	40707	02C2h
DI2 Input logic operation OR	40708	02C3h
DI3 Input option	40709	02C4h
DI3 Input logic operation AND	40711	02C6h
DI3 Input logic operation OR	40712	02C7h
DI4 Input option	40713	02C8h
DI4 Input logic operation AND	40715	02CAh
DI4 Input logic operation OR	40716	02CBh
DI5 Input option	40717	02CCh
DI5 Input logic operation AND	40719	02CEh
DI5 Input logic operation OR	40720	02CFh
DI6 Input option	40721	02D0h
DI6 Input logic operation AND	40723	02D2h
DI6 Input logic operation OR	40724	02D3h
DI7 Input option	40725	02D4h
DI7 Input logic operation AND	40727	02D6h
DI7 Input logic operation OR	40728	02D7h

## 5.7 Address Map and Data Format

---

<b>Content</b>	<b>Register No.</b>	<b>Relative address</b>
D18 Input option	40729	02D8h
D18 Input logic operation AND	40731	02DAh
D18 Input logic operation OR	40732	02DBh
Internal DO data area 1	41001	03E8h
Internal DO data area 2	41002	03E9h
Internal DO data area 3	41003	03EAh
Internal DO data area 4	41004	03EBh
Internal DO data area 5	41005	03ECh
Internal DO data area 6	41006	03EDh
Internal DO data area 7	41007	03EEh
Internal DO data area 8	41008	03EFh
Internal DO data area 9	41009	03F0h
Internal DO data area 10	41010	03F1h
Internal DO data area 11	41011	03F2h
Internal DO data area 12	41012	03F3h
Internal DO data area 13	41013	03F4h
Internal DO data area 14	41014	03F5h
Internal DO data area 15	41015	03F6h
Internal DO data area 16	41016	03F7h
System FAULT status	30064	003Fh
Digital input calculated result monitor	31001	03E8h
Digital output calculated result monitor	31002	03E9h
Digital input terminal monitor	31003	03EAh

# 5.8 Sample Program

A sample program for reading and writing data that runs on Microsoft Visual Basic 6.0 (SP6) is distributed in our home page.

**The sample program is meant to be used as a reference for your own program creation, and therefore all its actions are not guaranteed.**

Sample program body can be downloaded from our home page indicated below.

Home page address : <http://www.fic-net.jp/> PUM\_Sample\_program.lzh

Before running the program, check the following summary of points for communication conditions.

- Parity, communication speed to be set in this program. Please match these values with the conditions of the PUM.

### Warning when using an RS-232C to RS-485 converter

The sent data is sometimes added to the response data from the slave before it is received. In this case, when receiving the data, process the response data only after first getting rid of the number of bytes from the sent data.

Compatible OS

Windows 2000 Professional

Windows XP Professional Edition

#### Note

- Windows® is a registered trademark of the Microsoft Corporation.
- Visual Basic® is a registered trademark of the Microsoft Corporation.

Fuji Electric Systems Co., Ltd. assumes no responsibility for damages or infringement upon third party rights as a result of using this sample program.

Use this program while conforming to the contents of the agreement listed within.

# 6

## Troubleshooting

6.1	Troubleshooting Procedures .....	6-3
-----	----------------------------------	-----



# 6.1 Troubleshooting Procedures

## Troubles that May Occur when the Loader Software is Connected

The following table lists troubles that may occur when module setting is made using a loader software and remedies against such troubles.

Also see the instruction manual of the loader software.

Troubles	Causes	Solutions
None of the connected modules is capable of communicating with the loader software.	Improper loader software connection	Check that the loader software and the modules are connected properly.
	Cables connected to the loader software are defective.	Replace the cables connected to the loader software.
	Improper station No. setting	Check station No. of module that connected with loader software.
	Incompatible communication conditions	Check that the communication specifications of the loader software and those of the module are compatible.
Some of the connected modules only cannot communicate with the loader software.	Improper loader software connection	Check that the loader software is connected to the master of the internal communication between modules.
	Improper station No. setting	Check that none of the station Nos. is set duplicated.
Parameters cannot be changed.	“RS-485 communication permission setting” is set to “Read only.”	Set “RS-485 communication permission setting” to “Read/Write.”

## Troubles During Operation

If troubles should occur during operation, check the type of your module and its connection as well as parameter setting for any abnormalities. The following table lists typical troubles and measures to be taken against them.

### At power ON

Troubles	Causes	Solutions
The PWR indicator does not come on even if the power is turned on.	Power is not supplied to the main unit.	Check that power supply wiring is installed.
	Power supply voltage does not fall within the permissible range.	Use a power supply conforming to the main unit specifications.
	Main unit failure	Replace the module.
DI or DO is not output properly even if the power is turned on.	Standby is selected.	Select RUN instead of Standby.
Unexpected DO is output on turning on the power.	Setting has been made to allow DO to be output when operation for production is not performed.	Check the values set for DO parameters. Change the setting of the control module as required.
System fault occurs. (PWR Lamp, Red Lighting)	Designated DO master module St. does not exist.	Change the DO master module St. No. to the one of existing modules.
	Duplication of the master station	Designate only one module as the master in the parameter "Master/slave setting in connected modules" of the control module.
	Duplication of the station No.	Select the station No., using the rotary switch on the terminal block on the front face, avoiding duplicated selection.

**At start of operation**

Troubles	Causes	Solutions
DI is not input.	Improper DI input connection	Check the DI input connection.
	Improper setting in the control module.	Check the DI master module St. setting in the control module.
	Main unit failure	Replace the module. Make sure overvoltage or surge noise is not impressed on DI terminal.
DO is not output. (Event output)	Improper output type selection	Set the output type to "0: Event output."
	Improper DO master module St. No. or DO master module Ch. No.	Check DO master module St. No. and DO master module Ch. No.
	"NOT" is selected as an output option.	Select an output option conforming to the specifications.
DO is not output. (Control output)	Improper output selection	Set the output type to "1: Control output."
	Improper DO master module St. No. or DO master module Ch. No.	Check DO master module St. No. and DO master module Ch. No.
DO output proportional action (the timing of ON/OFF) does not operate as intend.	Improper scaling base or scaling span setting	Check the scaling base and scaling span settings.
	Improper proportional cycle	Check the proportional cycle and the MV value of the DO master module.
DO output does not OFF.	"LATCH" is selected as an output option.	Select an output option conforming to the specifications.
	Output device (relay or transistor) is broken.	Replace the module. Make sure that overvoltage/overcurrent or surge noise is not impressed on DO terminal.



**During operation**

Troubles	Causes	Solutions
Abnormal DO output	Effect of external noise	Take measures against noise.
Abnormal LED indicator display	Abnormal internal communication between modules	<p>&lt;About the LED indicator display&gt;                      If either one of the following state is reached, the "RUN" LED indicator may come on in red, indicating that the internal communication error between modules is occurring.</p> <ul style="list-style-type: none"> <li>• Station No. is duplicated in the connected modules. (The RUN indicator of the master station comes on in red in this case.)</li> <li>• There is a module its communication comes off. (The RUN indicator for all the stations come on in red in this case.)</li> </ul>

**Troubles with RS-485 Communication**

The following table lists typical trouble in communication and measures to be taken for the case in which a host equipment is connected via RS-485.

Trouble	Causes	Solution
Communication cannot be made from the host equipment.	Improper RS-485 connection	Check the polarity of the wiring and the existence of terminating resistance.
	Improper station No. setting	Check that none of the station Nos. is duplicated.
	Incompatible communication conditions	Check "RS-485 Communication speed" setting, "RS-485 Parity" setting, and "RS-485 Response interval time" setting.
Error messages are returned to the host equipment.	An improper address is accessed.	Check that proper addresses are accessed.
Parameters cannot be changed by way of host equipment.	Values that do not fall within the limit range are written.	Check that the values to be written fall within the limit range.
	"RS-485 communication permission" is set to "0:Read only."	Set "RS-485 communication permission" to "1:Read/Write."

# Index

---

## A

- Accessories ..... 1-4,3-11
- Analog input/output module ..... 2-3,3-10
- AND calculation specification..... 4-8,4-20

## B

- Base part ..... 1-5,1-7,3-6,3-7,3-8,3-12
- Broadcast query ..... 5-3

## C

- Coil number ..... 5-14,5-16
- Command message.....5-12,5-14,5-18
- Communication condition ..... 5-10
- Communication Fault between enhanced communication module (internal) ..... 4-43
- Communication parameter ..... 5-34
- Communication specification ..... 5-5
- Configuration parameter ..... 5-34
- Connected module master/slave setting ..... 2-4,6-4
- Control module ..... 1-3,2-3,3-3,3-10,4-5,4-7,4-16
- Control output ..... 4-17,4-31,4-32
- Crimp terminal ..... 3-14

## D

- DI AND setting ..... 4-11
- DI calculated result monitor ..... 4-41
- DI latch releases command ..... 4-5
- DI latch signal ..... 4-5
- DI latch specification ..... 4-8,4-9
- DI NOT setting ..... 4-10
- DI option..... 4-8
- DI OR setting..... 4-13
- DI signal ..... 4-5
- DI terminal monitor ..... 4-42
- DI terminal ..... 4-7,4-9,4-42
- Digital input parameter ..... 5-30
- Digital input ..... 3-13,4-7
- Digital output parameter ..... 5-31
- Digital output ..... 3-13,4-16

- Dimensions ..... 3-5
- DO BIT position specification ..... 4-19
- DO calculated result monitor ..... 4-40
- DO latch release command ..... 4-4
- DO latch signal ..... 4-4
- DO latch specification ..... 4-20,4-21
- DO limit type ..... 4-29
- DO master Channel number ..... 4-18
- DO master station number ..... 4-18
- DO operation during Fault ..... 4-33
- DO output AND setting ..... 4-23
- DO output limit ..... 4-29
- DO output NOT setting ..... 4-22
- DO output option ..... 4-20
- DO output OR setting ..... 4-25
- DO output terminal ..... 4-16,4-21
- DO output type ..... 4-17
- DO proportional cycle ..... 4-28
- DO scaling base ..... 4-27
- DO scaling span ..... 4-27
- DO signal ..... 4-4

## E

- End plates ..... 3-11
- Enhanced communication module (PUMC) connection permission ..... 4-37
- Enhanced communication module ..... 3-10,4-37,4-43
- Error check cord ..... 5-14,5-17
- Event input/output module ..... 1-3,2-3,3-10
- Event output ..... 4-17,4-19,4-31,4-32

## F

- FAULT OUT1 set value ..... 4-33
- Fault status ..... 4-19
- Frame detection ..... 5-18
- Front terminal block ..... 1-5,1-6,3-6
- Function cord ..... 5-14,5-16

<b>I</b>		
Installation dimensions	.....	3-5
Insulation	.....	3-13
Intermodule communication	.....	4-7,4-16
Internal DO area	.....	4-16,4-21,4-31
<b>L</b>		
LED indicator lamp	.....	1-6,2-4
LED lamps	.....	4-44
LED lighting condition setting	.....	4-44
LED2 lamp allocation	.....	4-44
Loader communication port	.....	1-6,5-7
Loader connecting cable	.....	1-6,5-3,5-7,5-9
Loader interface	.....	5-6
Lock lever	.....	3-6,3-7
Locking tab	.....	1-7,3-8,3-9,3-12
<b>M</b>		
Main unit	.....	1-5
Master module communication method	.....	5-18
Master/slave setting	.....	2-4
Master	.....	2-4,3-10,4-18,4-21,5-3,5-12
Message composition	.....	5-14
MODBUS communication protocol	.....	5-12
Model code	.....	1-4
Monitor parameter	.....	5-34
Mounting screw hole	.....	1-7
Mounting screw	.....	3-12
<b>N</b>		
No response	.....	5-15,5-17,5-18
NOT calculation specification	.....	4-8,4-20
<b>O</b>		
Operation parameter	.....	5-29
OR calculation specification	.....	4-8,4-20
<b>P</b>		
Power terminal	.....	1-7,3-14
PUM parameter loader software	.....	1-6,2-3
<b>R</b>		
Recommended power supply	.....	4
Register number	.....	5-36
Response message	.....	5-14,5-15,5-16,5-19
RS-485 communication permission setting	.....	4-36
RS-485 communication speed setting	.....	4-36
RS-485 interface	.....	5-3,5-18
RS-485 parity setting	.....	4-36
RS-485 response interval time setting	.....	4-37
RS-485 terminal	.....	1-7,3-14
RUN / Standby switch	.....	4-5
<b>S</b>		
Sample program	.....	5-39
Side connecting terminal covers	.....	3-11
Side connector	.....	1-7,3-9,3-11
Slave	.....	2-4,3-3,3-10,5-3,5-8,5-12
Standby mode setting	.....	4-32
Standby mode	.....	4-5,4-19
Standby operation	.....	4-32
Standby output set value	.....	4-32
Station number	.....	1-6,2-4,3-10,5-3,5-10,5-12
System configuration	.....	2-3
System FAULT STATUS	.....	4-43
<b>T</b>		
Terminal layout	.....	3-13,3-14
Terminal resistance	.....	3-15,5-8
Transmission control steps	.....	5-18
<b>W</b>		
Wiring for input/output	.....	3-13
Wiring for power supply	.....	3-14
Wiring for RS-485	.....	3-14

---

## **Fuji Electric Systems Co., Ltd.**

### **Head Office**

Gate City Ohsaki, East Tower, 11-2, Osaki 1-chome,  
Shinagawa-ku, Tokyo 141-0032, Japan  
<http://www.fesys.co.jp/eng>

### **Instrumentation Div.**

#### **International Sales Dept.**

No.1, Fuji-machi, Hino-city, Tokyo 191-8502, Japan  
Phone: 81-42-585-6201, 6202 Fax: 81-42-585-6187  
<http://www.fic-net.jp/eng>

---